



# BAT32G135 Datasheet

**LowPower-line Arm®-based 32-bit MCU with up to 64KB Flash,**

**Analog functions, Timers and Communication interfaces.**

**V1.40**

Please note the following Policy relating to the CMS Intellectual Property

\* China Micro Semicon Co., Ltd., has applied for a patent and enjoys absolute legal rights. The patents related to MCU or other products of China Micro Semicon Co., Ltd., have not been authorized for use. Any company, organization or individual that infringes the patent rights of China Micro Semicon Co., Ltd., improperly, China Micro Semicon Co., Ltd., will take all possible legal actions to stop the infringer's improper infringement, and command the payment from the losses of China Micro Semicon Co., Ltd., due to the infringement, or the illegal interests from the infringer.

\* The name and logo of China Micro Semicon Co., Ltd., are registered trademarks of China Micro Semicon Co., Ltd.

\* China Micro Semicon Co., Ltd., reserves the right to further explain the improvements in reliability, functionality and design of the products in the specification. And China Micro Semicon Co., Ltd., is not responsible for the use of the specifications. The application mentioned in the article is only for the purpose of illustration, and China Micro Semicon Co., Ltd., does not ensure or declare that these applications may be applied without further modifications, and it's not recommended to use its products in areas that may be hazardous to human body due to malfunction or other reasons. China Micro Semicon Co., Ltd.,'s products are not authorized for using as a critical device in life-saving, life-sustaining devices or systems. China Micro Semicon Co., Ltd., has the right to modify the product without prior notice. If you want to get the latest information, please refer to our website. <http://www.mcu.com.cn>

## Features

- **Ultra-low power consumption technology**
  - Operating Voltage: 1.8V~5.5V
  - Operating ambient temperature: -40°C~105°C
  - Low power modes: SLEEP, DEEPSLEEP
  - Operating power consumption:
    - RUN mode: 35uA/MHz@64MHz
    - DEEPSLEEP mode: 0.45uA
    - DEEPSLEEP mode (+32.768K+RTC): 0.7uA
- **Core**
  - ARM®32-bit Cortex®-M0+ CPU
  - Operating frequency: 32KHz~64MHz
- **Memories**
  - 64KB Flash Memory: program/data flash
  - 1.5KB Special data flash memory
  - 8KB SRAM Memory (With Parity)
- **Reset and power management**
  - Power-on reset circuit.
  - On-chip voltage detector (LVD) (Select interrupt and reset level by option byte)
- **Clock**
  - Main clock oscillator: 1MHz to 64MHz
  - Sub clock oscillator: 32.768KHz
  - High-speed on-chip oscillator: 1MHz to 20MHz, accuracy ( $\pm 1\%$ )
  - Low-speed on-chip oscillator: 15KHz
- **Multiplier**
  - Integer multiplier
- **DMA**
  - Interrupt trigger start.
  - Transfer modes: Normal mode, Repeat mode, Block mode and Chain transfers mode
  - Transfer space: 4 GB area from 0000 0000h to FFFF FFFFh except reserved areas
- **EVENTC**
  - Event Link Controller
  - Event signals (15 types) can be used as activation sources for operating any one of 4 types of peripheral functions
- **Analog**
  - 12-Bit A/D Converter
    - Conversion range: 0 to Vrefp or VDD
    - Analog input: Up to 15 channels, Internal reference voltage (1.45 V) and temperature sensor
    - Conversion rate: 1.42MSPS
  - Comparator (CMP) × 2: The external reference voltage or internal reference voltage can be selected as the reference voltage
  - Programmable gain amplifier (PGA) × 2: GAIN x4/8/10/12/14/16/32 can be selected
- **GPIO**
  - I/O port: 29 to 45
  - Can be set to N-ch open drain and on-chip pull-up resistor
  - Digital function can be freely assigned to any pin
  - On-chip clock output/buzzer output controller
- **Serial wire debug (SWD)**
- **Timers**
  - 16-bit timer: 8 channels
  - 15-bit interval timer: 1 channel
  - Real-time clock (RTC): 1 channel
  - Watchdog timer (WWDT): 1 channel (operable with the dedicated low-speed on-chip oscillator)
  - SysTick timer
- **Serial interfaces**
  - SCI: 3 channels (1 UART / 2 SPI / 2 I2C for each SCI channel)
  - Standard SPI: 1 channel (8bit or 16bit)
  - Standard I2C: 1 channel
  - IrDA: 1 channel
- **Safety**
  - IEC/UL 60730
  - Illegal memory access
  - SRAM Parity Error Check
  - Cyclic Redundancy Check (CRC) Calculator
  - SFR protection
  - 128-bit unique ID
  - Flash secondary protection in debug mode (level1: only erase the entire area of flash; level2: the emulator connection is invalid)
- **Packages**
  - 48LQFP, 40QFN, 32LQFP, 32QFN

# 1 Overview

## 1.1 Introduction

The ultra-low-power BAT32G135 incorporates a high-performance ARM®Cortex®-M0+ 32-bit RISC core running up to 64 MHz and high-speed embedded flash memory (SRAM maximum 8KB, program/data flash 64KB). This product integrates I2C, SPI, UART, LIN multiple standard interfaces. Integrated 12bitA/D converter, temperature sensor, 8bitD/A converter, comparator, programmable gain amplifier. Among them, the 12bitA/D converter can collect external sensor signals to reduce the system design cost. The temperature integrated sensor can realize real-time monitoring of the external ambient temperature. The inner comparator can support high-speed and low-speed operating modes. In high-speed mode, it can support high-speed motor control feedback, and in low-speed mode, it can be used for battery monitoring. Integrated 8-channel 16bit timer module with EPWM control circuit, combined with the timer can realize the control of a DC motor or two stepper motors.

BAT32G135 has particularly excellent low-power performance, with two low-power modes of sleep and deep sleep, to flexible design for users. Its operating power consumption is 35uA/MHz@64MHz, and the power consumption in deep sleep mode is only 0.45uA, which is suitable for battery-powered low-power devices. At the same time, due to the integrated event link controller, direct connection between hardware modules can be achieved without CPU intervention, which is faster than the use of interrupt response, while reducing the CPU's activity frequency and extending battery life.

These characteristics make the BAT32G135 microcontroller series widely applicable to alarm, sensor, smart locks and other smart home equipment, wireless monitoring equipment, portable devices that require power consumption, etc.

## 1.2 Ordering Information

Figure 1 - 1 Part Number, Memory Size, and Package of BAT/G135

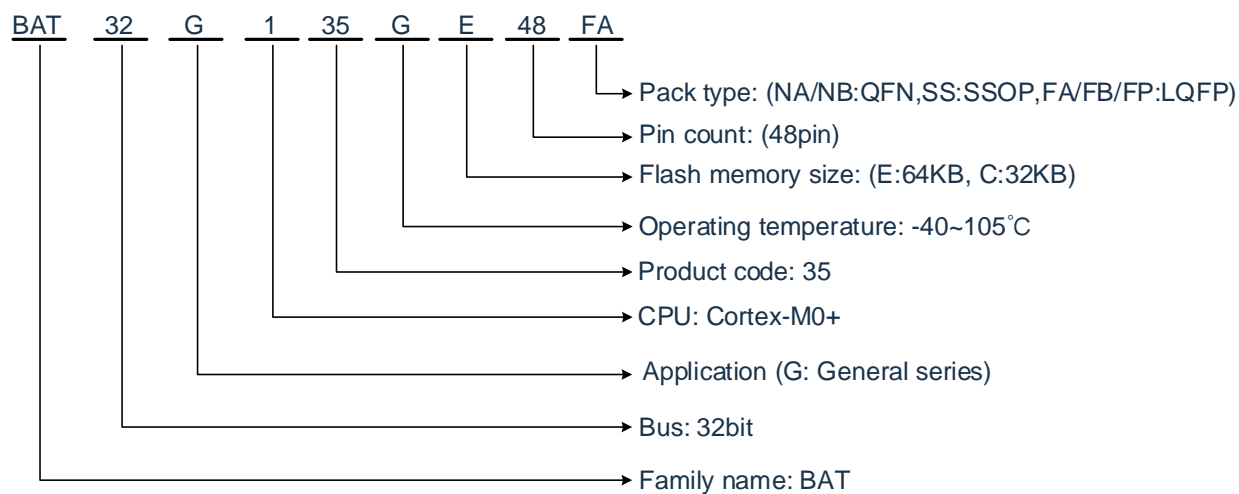

Product list:

| Pin count | Package                      | Ordering Part Number |
|-----------|------------------------------|----------------------|
| 32 pins   | 32 LQFP (7x7mm, 0.8mm pitch) | BAT32G135GE32FP      |
| 32 pins   | 32 QFN (5x5mm, 0.5mm pitch)  | BAT32G135GE32NA      |
| 40 pins   | 40 QFN (5x5mm, 0.4mm pitch)  | BAT32G135GE40NB      |
| 48 pins   | 48 LQFP (7x7mm, 0.5mm pitch) | BAT32G135GE48FA      |

FLASH, SRAM:

| Flash memory | Special data flash memory | SRAM | 32 Pins / 40 Pins / 48 Pins |               |               |
|--------------|---------------------------|------|-----------------------------|---------------|---------------|
| 64KB         | 1.5KB                     | 8KB  | BAT32G135GE32               | BAT32G135GE40 | BAT32G135GE48 |

## BAT32G135 Product list:

| Part No.            | Core | Operating frequency (MHz) | 最低工作电压 (V) | 最高工作电压 (V) | Code Flash (KB) | SRAM (KB) | Data Flash (KB) | DMA | GPIO | 12bit ADC | 比较器 CMP | 放大器 PGA | 通用定时器 (16bit) | 实时时钟 (RTC) | 看门狗定时器 (WDT) | 异步串行总线 (UART) | 同步串行总线 (SPI) | IIC总线 | I2DA总线 | 硬件乘法器 | 硬件除法器 | 封装 (package) |
|---------------------|------|---------------------------|------------|------------|-----------------|-----------|-----------------|-----|------|-----------|---------|---------|---------------|------------|--------------|---------------|--------------|-------|--------|-------|-------|--------------|
| BAT32G135<br>GE32FP | M0+  | 64                        | 1.8        | 5.5        | 64              | 8         | 1.5             | 24  | 29   | 25+<br>3  | 2       | 1       | 8             | 1          | 1            | 3             | 1+3          | 1+3   | 1      | Y     | Y     | LQFP<br>32   |
| BAT32G135<br>GE32NA | M0+  | 64                        | 1.8        | 5.5        | 64              | 8         | 1.5             | 24  | 29   | 25+<br>4  | 2       | 1       | 8             | 1          | 1            | 3             | 1+3          | 1+3   | 1      | Y     | Y     | QFN<br>32    |
| BAT32G135<br>GE40NB | M0+  | 64                        | 1.8        | 5.5        | 64              | 8         | 1.5             | 24  | 37   | 28+<br>4  | 2       | 2       | 8             | 1          | 1            | 3             | 1+4          | 1+4   | 1      | Y     | Y     | QFN<br>40    |
| BAT32G135<br>GE48FA | M0+  | 64                        | 1.8        | 5.5        | 64              | 8         | 1.5             | 24  | 45   | 35+<br>4  | 2       | 2       | 8             | 1          | 1            | 3             | 1+5          | 1+5   | 1      | Y     | Y     | LQFP<br>48   |

## 1.3 Pin Configuration (Top View)

### 1.3.1 BAT32G135GE32FP

- 32LQFP (7x7mm, 0.8mm pitch)

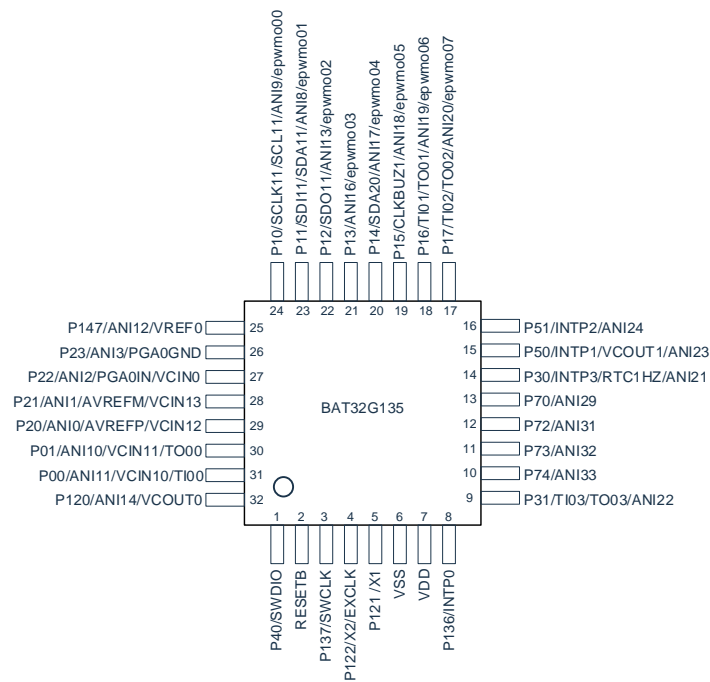

Remark: Digital function supports pins that are not marked in the figure can be configured. Refer to section 4.1

## 1.3.2 BAT32G135GE32NA

- 32QFN (5x5mm, 0.5mm pitch)

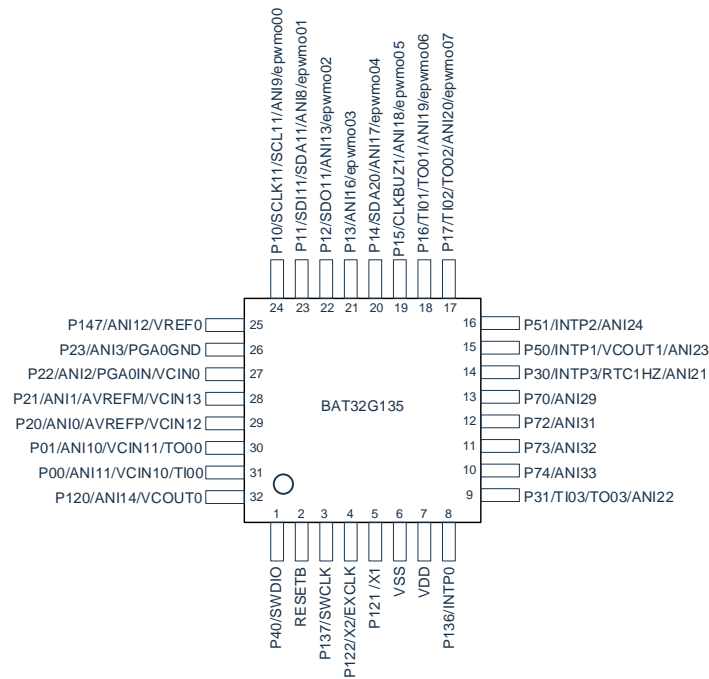

Remark: Digital function supports pins that are not marked in the figure can be configured. Refer to section 4.1

### 1.3.3 BAT32G135GE40NB

- 40QFN (5x5mm, 0.4mm pitch)

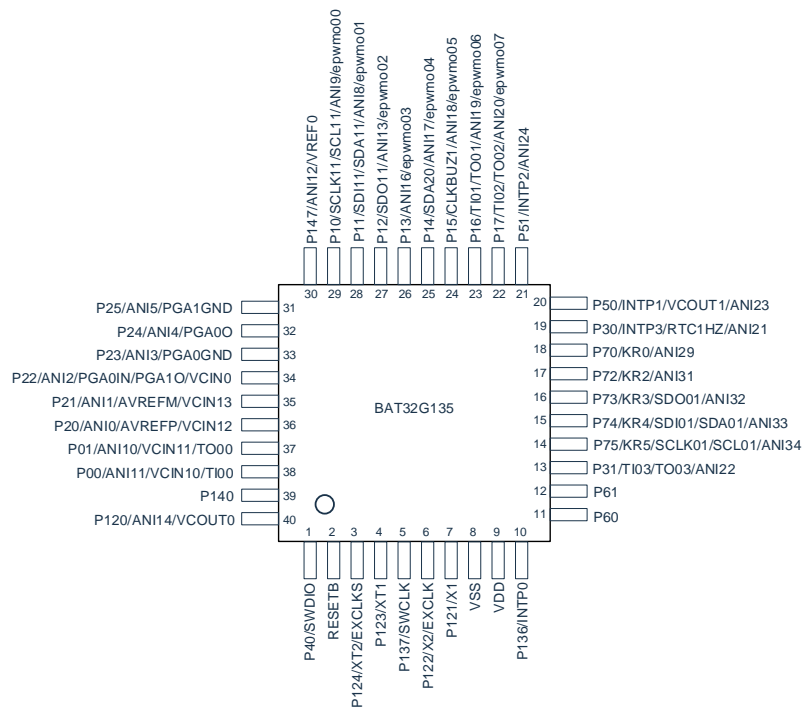

Remark: Digital function supports pins that are not marked in the figure can be configured. Refer to section 4.1



## 1.3.4 BAT32G135GE48FA

- 48LQFP (7x7mm, 0.5mm pitch)

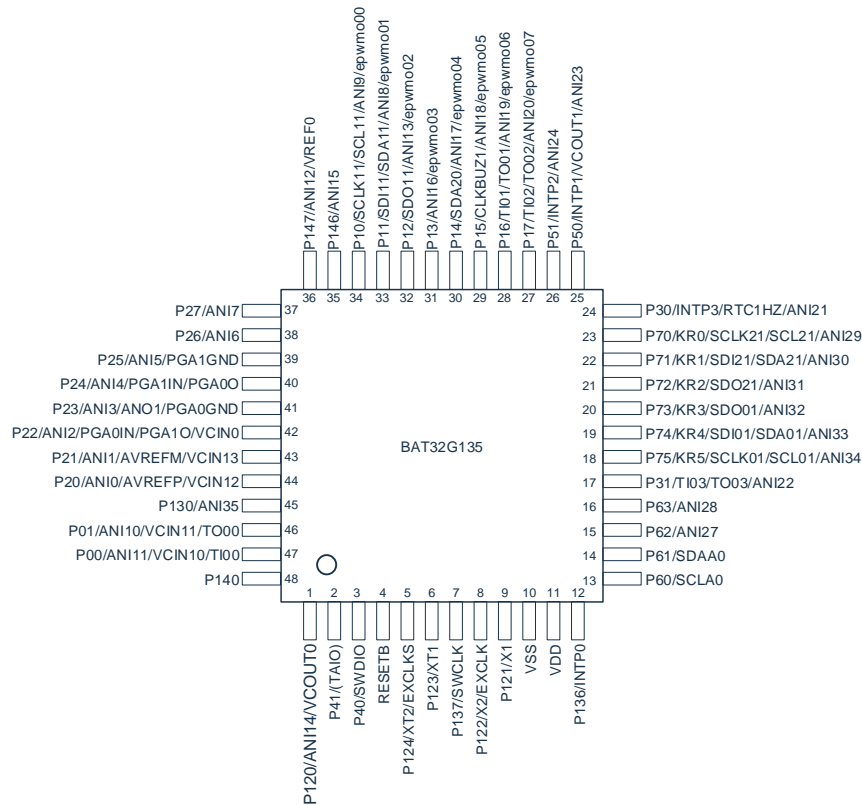

Remark: Digital function supports pins that are not marked in the figure can be configured. Refer to section 4.1

# 2 Block Diagram

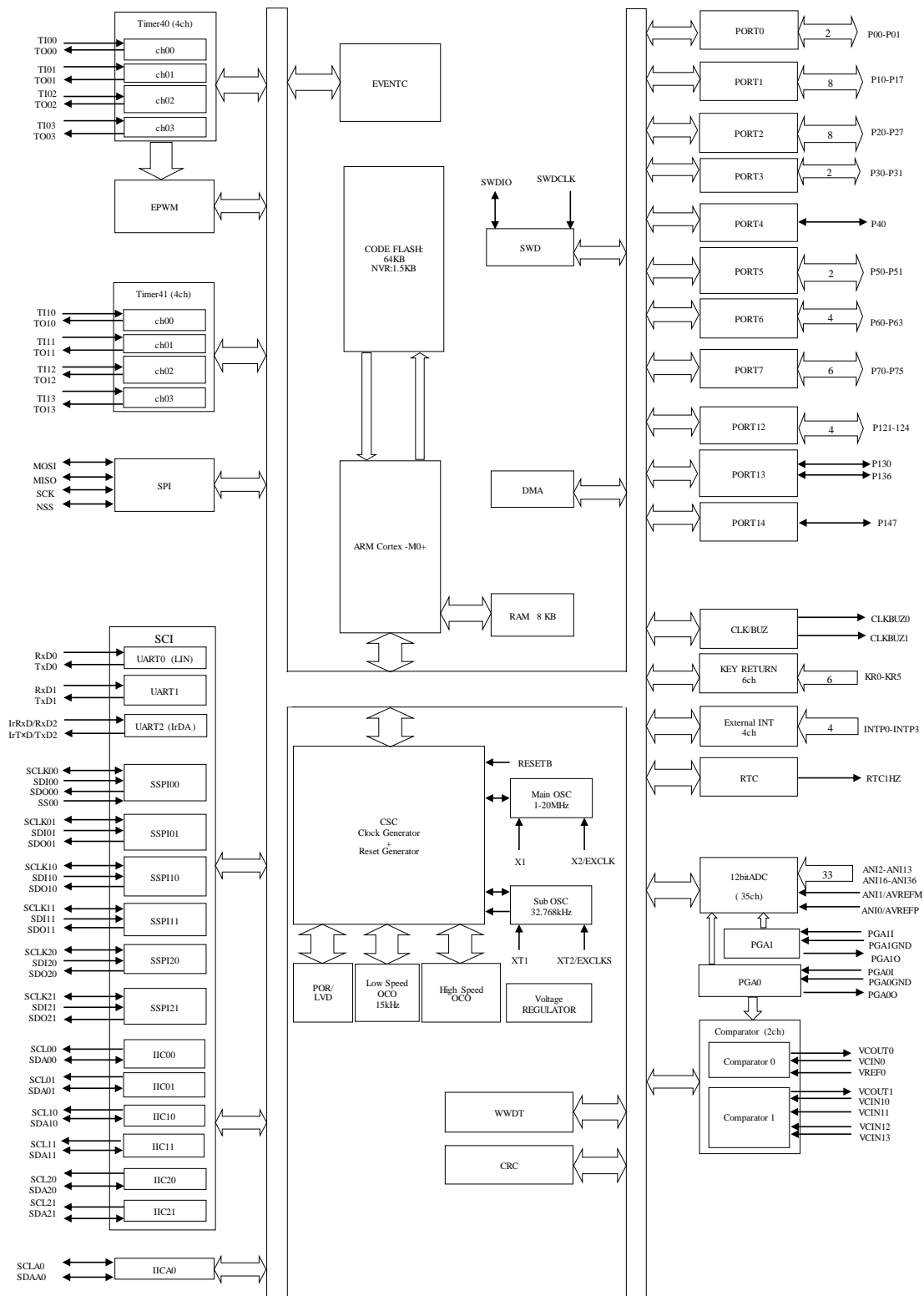

## 3 Memory Space

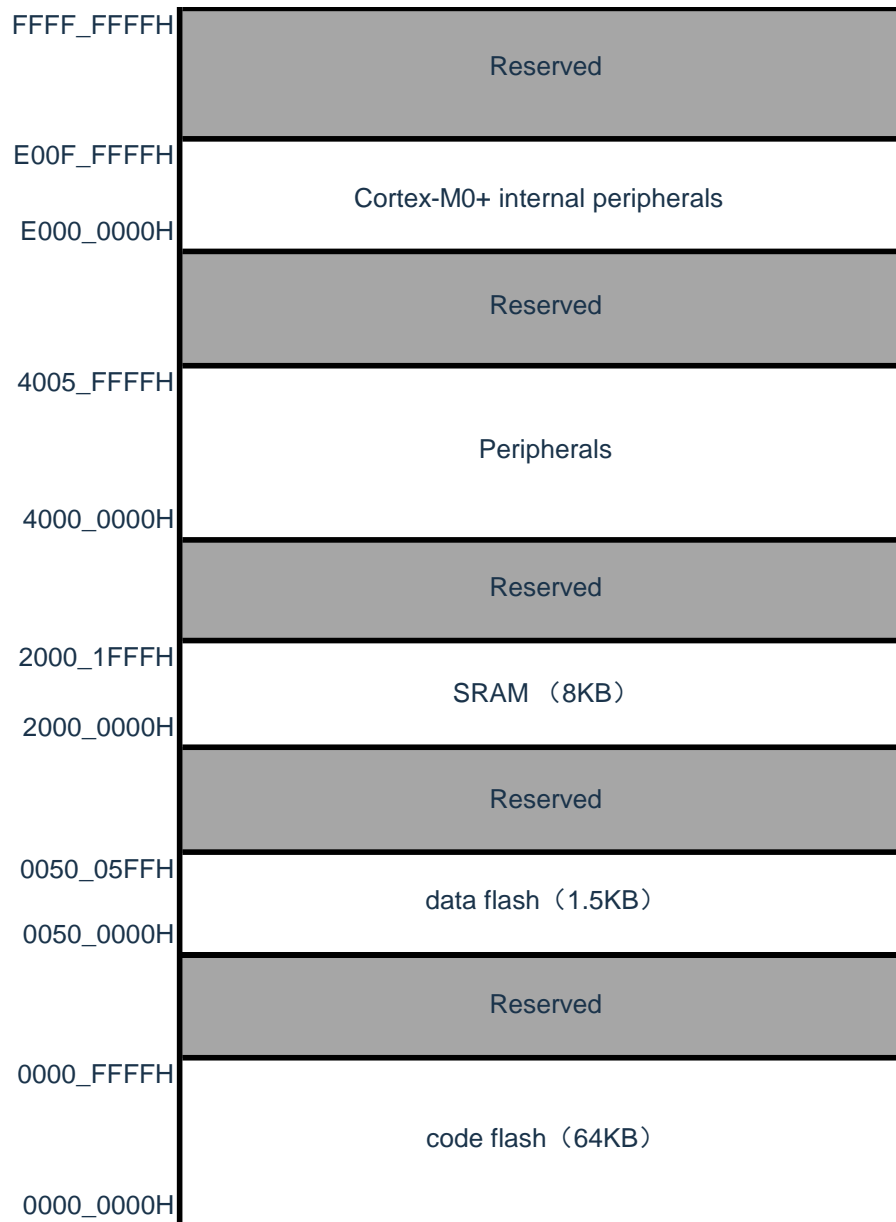

# 4 PIN Functions

## 4.1 Port Functions

Table 4.1.1

| Port Name | Alternate Function | Digital output function configuration register pxxcfg[3:0] | Digital input function configuration register xxxPCFG[5:0] | Function built-in or not |       |                 |
|-----------|--------------------|--|--|--------------------------|-------|-----------------|
|           |                    |  |  | 48LQFP                   | 40QFN | 32LQFP<br>32QFN |
| RESETB    | RESETB             | -  | -  | ●                        | ●     | ●               |
| P00       | GPIO               | 00H  | 00H  | ●                        | ●     | ●               |
|           | ANI11              | 00H  | 00H  | ●                        | ●     | ●               |
|           | VCIN10             | 00H  | 00H  | ●                        | ●     | ●               |
|           | TI00               | 00H  | 00H  | ●                        | ●     | ●               |
|           | Digital function   | X (Refer to table 4.1.2)                                   | X (Refer to table 4.1.2)                                   | ●                        | ●     | ●               |
| P01       | GPIO               | 00H  | 00H  | ●                        | ●     | ●               |
|           | ANI10              | 00H  | 00H  | ●                        | ●     | ●               |
|           | VCIN11             | 00H  | 00H  | ●                        | ●     | ●               |
|           | TO00               | 00H  | 00H  | ●                        | ●     | ●               |
|           | Digital function   | X (Refer to table 4.1.2)                                   | X (Refer to table 4.1.2)                                   | ●                        | ●     | ●               |
| P10       | GPIO               | 00H  | 00H  | ●                        | ●     | ●               |
|           | ANI9               | 00H  | 00H  | ●                        | ●     | ●               |
|           | SCLK11             | 00H  | 00H  | ●                        | ●     | ●               |
|           | SCL11              | 00H  | 00H  | ●                        | ●     | ●               |
|           | EPWMO00            | 00H  | 00H  | ●                        | ●     | ●               |
|           | Digital function   | X (Refer to table 4.1.2)                                   | X (Refer to table 4.1.2)                                   | ●                        | ●     | ●               |
| P11       | GPIO               | 00H  | 00H  | ●                        | ●     | ●               |
|           | ANI8               | 00H  | 00H  | ●                        | ●     | ●               |
|           | SDI11              | 00H  | 00H  | ●                        | ●     | ●               |
|           | SDA11              | 00H  | 00H  | ●                        | ●     | ●               |
|           | EPWMO01            | 00H  | 00H  | ●                        | ●     | ●               |
|           | Digital function   | X (Refer to table 4.1.2)                                   | X (Refer to table 4.1.2)                                   | ●                        | ●     | ●               |
| P12       | GPIO               | 00H  | 00H  | ●                        | ●     | ●               |
|           | ANI13              | 00H  | 00H  | ●                        | ●     | ●               |
|           | SDO11              | 00H  | 00H  | ●                        | ●     | ●               |
|           | EPWMO02            | 00H  | 00H  | ●                        | ●     | ●               |
|           | Digital function   | X (Refer to table 4.1.2)                                   | X (Refer to table 4.1.2)                                   | ●                        | ●     | ●               |
| P13       | GPIO               | 00H  | 00H  | ●                        | ●     | ●               |
|           | ANI16              | 00H  | 00H  | ●                        | ●     | ●               |
|           | EPWMO03            | 00H  | 00H  | ●                        | ●     | ●               |
|           | Digital function   | X (Refer to table 4.1.2)                                   | X (Refer to table 4.1.2)                                   | ●                        | ●     | ●               |

|     |                  |                          |                          |   |   |   |
|-----|------------------|--------------------------|--------------------------|---|---|---|
| P14 | GPIO             | 00H                      | 00H                      | ● | ● | ● |
|     | ANI17            | 00H                      | 00H                      | ● | ● | ● |
|     | SDA20            | 00H                      | 00H                      | ● | ● | ● |
|     | EPWMO04          | 00H                      | 00H                      | ● | ● | ● |
|     | Digital function | X (Refer to table 4.1.2) | X (Refer to table 4.1.2) | ● | ● | ● |
| P15 | GPIO             | 00H                      | 00H                      | ● | ● | ● |
|     | ANI18            | 00H                      | 00H                      | ● | ● | ● |
|     | CLKBUZ1          | 00H                      | 00H                      | ● | ● | ● |
|     | EPWMO05          | 00H                      | 00H                      | ● | ● | ● |
|     | Digital function | X (Refer to table 4.1.2) | X (Refer to table 4.1.2) | ● | ● | ● |
| P16 | GPIO             | 00H                      | 00H                      | ● | ● | ● |
|     | ANI19            | 00H                      | 00H                      | ● | ● | ● |
|     | TI01             | 00H                      | 00H                      | ● | ● | ● |
|     | TO01             | 00H                      | 00H                      | ● | ● | ● |
|     | (SPIMOSI)        | 00H                      | 00H                      | ● | ● | ● |
|     | EPWMO06          | 00H                      | 00H                      | ● | ● | ● |
|     | Digital function | X (Refer to table 4.1.2) | X (Refer to table 4.1.2) | ● | ● | ● |
| P17 | GPIO             | 00H                      | 00H                      | ● | ● | ● |
|     | ANI20            | 00H                      | 00H                      | ● | ● | ● |
|     | TI02             | 00H                      | 00H                      | ● | ● | ● |
|     | TO02             | 00H                      | 00H                      | ● | ● | ● |
|     | (SPIMISO)        | 00H                      | 00H                      | ● | ● | ● |
|     | EPWMO07          | 00H                      | 00H                      | ● | ● | ● |
|     | Digital function | X (Refer to table 4.1.2) | X (Refer to table 4.1.2) | ● | ● | ● |
| P20 | GPIO             | 00H                      | 00H                      | ● | ● | ● |
|     | ANI0             | 00H                      | 00H                      | ● | ● | ● |
|     | AVREFP           | 00H                      | 00H                      | ● | ● | ● |
|     | VCIN12           | 00H                      | 00H                      | ● | ● | ● |
|     | Digital function | X (Refer to table 4.1.2) | X (Refer to table 4.1.2) | ● | ● | ● |
| P21 | GPIO             | 00H                      | 00H                      | ● | ● | ● |
|     | ANI1             | 00H                      | 00H                      | ● | ● | ● |
|     | AVREFM           | 00H                      | 00H                      | ● | ● | ● |
|     | VCIN13           | 00H                      | 00H                      | ● | ● | ● |
|     | Digital function | X (Refer to table 4.1.2) | X (Refer to table 4.1.2) | ● | ● | ● |
| P22 | GPIO             | 00H                      | 00H                      | ● | ● | ● |
|     | ANI2             | 00H                      | 00H                      | ● | ● | ● |
|     | PGA0IN           | 00H                      | 00H                      | ● | ● | ● |
|     | PGA10            | 00H                      | 00H                      | ● | ● | - |
|     | VCIN0            | 00H                      | 00H                      | ● | ● | ● |
|     | Digital function | X (Refer to table 4.1.2) | X (Refer to table 4.1.2) | ● | ● | ● |
| P23 | GPIO             | 00H                      | 00H                      | ● | ● | ● |
|     | ANI3             | 00H                      | 00H                      | ● | ● | ● |

|     |                  |                          |                          |   |   |   |
|-----|------------------|--------------------------|--------------------------|---|---|---|
|     | PGA0GND          | 00H                      | 00H                      | ● | ● | ● |
|     | Digital function | X (Refer to table 4.1.2) | X (Refer to table 4.1.2) | ● | ● | ● |
| P24 | GPIO             | 00H                      | 00H                      | ● | ● | - |
|     | ANI4             | 00H                      | 00H                      | ● | ● | - |
|     | PGA1IN           | 00H                      | 00H                      | ● | ● | - |
|     | PGA00            | 00H                      | 00H                      | ● | ● | - |
|     | Digital function | X (Refer to table 4.1.2) | X (Refer to table 4.1.2) | ● | ● | - |
| P25 | GPIO             | 00H                      | 00H                      | ● | ● | - |
|     | ANI5             | 00H                      | 00H                      | ● | ● | - |
|     | PGA1GND          | 00H                      | 00H                      | ● | ● | - |
|     | Digital function | X (Refer to table 4.1.2) | X (Refer to table 4.1.2) | ● | ● | - |
| P26 | GPIO             | 00H                      | 00H                      | ● | - | - |
|     | ANI6             | 00H                      | 00H                      | ● | - | - |
|     | Digital function | X (Refer to table 4.1.2) | X (Refer to table 4.1.2) | ● | - | - |
| P27 | GPIO             | 00H                      | 00H                      | ● | - | - |
|     | ANI7             | 00H                      | 00H                      | ● | - | - |
|     | Digital function | X (Refer to table 4.1.2) | X (Refer to table 4.1.2) | ● | - | - |
| P30 | GPIO             | 00H                      | 00H                      | ● | ● | ● |
|     | ANI21            | 00H                      | 00H                      | ● | ● | ● |
|     | INTP3            | 00H                      | 00H                      | ● | ● | ● |
|     | RTC1HZ           | 00H                      | 00H                      | ● | ● | ● |
|     | Digital function | X (Refer to table 4.1.2) | X (Refer to table 4.1.2) | ● | ● | ● |
| P31 | GPIO             | 00H                      | 00H                      | ● | ● | ● |
|     | ANI22            | 00H                      | 00H                      | ● | ● | ● |
|     | TI03             | 00H                      | 00H                      | ● | ● | ● |
|     | TO03             | 00H                      | 00H                      | ● | ● | ● |
|     | Digital function | X (Refer to table 4.1.2) | X (Refer to table 4.1.2) | ● | ● | ● |
| P40 | GPIO             | 00H                      | 00H                      | ● | ● | ● |
|     | SWDIO            | 00H                      | 00H                      | ● | ● | ● |
|     | Digital function | X (Refer to table 4.1.2) | X (Refer to table 4.1.2) | ● | ● | ● |
| P41 | GPIO             | 00H                      | 00H                      | ● | - | - |
|     | Digital function | X (Refer to table 4.1.2) | X (Refer to table 4.1.2) | ● | - | - |
| P50 | GPIO             | 00H                      | 00H                      | ● | ● | ● |
|     | ANI23            | 00H                      | 00H                      | ● | ● | ● |
|     | INTP1            | 00H                      | 00H                      | ● | ● | ● |
|     | VCOOUT1          | 00H                      | 00H                      | ● | ● | ● |
|     | (SPINSS)         | 00H                      | 00H                      | ● | ● | ● |
|     | Digital function | X (Refer to table 4.1.2) | X (Refer to table 4.1.2) | ● | ● | ● |
| P51 | GPIO             | 00H                      | 00H                      | ● | ● | ● |
|     | ANI24            | 00H                      | 00H                      | ● | ● | ● |
|     | INTP2            | 00H                      | 00H                      | ● | ● | ● |
|     | (SPISCK)         | 00H                      | 00H                      | ● | ● | ● |

|     |                  |                          |                          |   |   |   |
|-----|------------------|--------------------------|--------------------------|---|---|---|
|     | Digital function | X (Refer to table 4.1.2) | X (Refer to table 4.1.2) | ● | ● | ● |
| P60 | GPIO             | 00H                      | 00H                      | ● | ● | - |
|     | Digital function | X (Refer to table 4.1.2) | X (Refer to table 4.1.2) | ● | ● | - |
| P61 | GPIO             | 00H                      | 00H                      | ● | ● | - |
|     | Digital function | X (Refer to table 4.1.2) | X (Refer to table 4.1.2) | ● | ● | - |
| P62 | GPIO             | 00H                      | 00H                      | ● | - | - |
|     | ANI27            | 00H                      | 00H                      | ● | - | - |
|     | Digital function | X (Refer to table 4.1.2) | X (Refer to table 4.1.2) | ● | - | - |
| P63 | GPIO             | 00H                      | 00H                      | ● | - | - |
|     | ANI28            | 00H                      | 00H                      | ● | - | - |
|     | Digital function | X (Refer to table 4.1.2) | X (Refer to table 4.1.2) | ● | - | - |
| P70 | GPIO             | 00H                      | 00H                      | ● | ● | ● |
|     | ANI29            | 00H                      | 00H                      | ● | ● | ● |
|     | KR0              | 00H                      | 00H                      | ● | ● | - |
|     | SCLK21           | 00H                      | 00H                      | ● | - | - |
|     | SCL21            | 00H                      | 00H                      | ● | - | - |
|     | Digital function | X (Refer to table 4.1.2) | X (Refer to table 4.1.2) | ● | ● | ● |
| P71 | GPIO             | 00H                      | 00H                      | ● | - | - |
|     | ANI30            | 00H                      | 00H                      | ● | - | - |
|     | KR1              | 00H                      | 00H                      | ● | - | - |
|     | SDI21            | 00H                      | 00H                      | ● | - | - |
|     | SDA21            | 00H                      | 00H                      | ● | - | - |
|     | Digital function | X (Refer to table 4.1.2) | X (Refer to table 4.1.2) | ● | - | - |
| P72 | GPIO             | 00H                      | 00H                      | ● | ● | ● |
|     | ANI31            | 00H                      | 00H                      | ● | ● | ● |
|     | KR2              | 00H                      | 00H                      | ● | ● | - |
|     | SDO21            | 00H                      | 00H                      | ● | - | - |
|     | Digital function | X (Refer to table 4.1.2) | X (Refer to table 4.1.2) | ● | ● | ● |
| P73 | GPIO             | 00H                      | 00H                      | ● | ● | ● |
|     | ANI32            | 00H                      | 00H                      | ● | ● | ● |
|     | KR3              | 00H                      | 00H                      | ● | ● | - |
|     | SDO01            | 00H                      | 00H                      | ● | ● | - |
|     | Digital function | X (Refer to table 4.1.2) | X (Refer to table 4.1.2) | ● | ● | ● |
| P74 | GPIO             | 00H                      | 00H                      | ● | ● | ● |
|     | ANI33            | 00H                      | 00H                      | ● | ● | ● |
|     | KR4              | 00H                      | 00H                      | ● | ● | - |
|     | SDI01            | 00H                      | 00H                      | ● | ● | - |
|     | SDA01            | 00H                      | 00H                      | ● | ● | - |
|     | Digital function | X (Refer to table 4.1.2) | X (Refer to table 4.1.2) | ● | ● | ● |
| P75 | GPIO             | 00H                      | 00H                      | ● | ● | - |
|     | ANI34            | 00H                      | 00H                      | ● | ● | - |
|     | KR5              | 00H                      | 00H                      | ● | ● | - |

|      |                  |                          |                          |   |   |   |
|------|------------------|--------------------------|--------------------------|---|---|---|
|      | SCLK01           | 00H                      | 00H                      | ● | ● | - |
|      | SCL01            | 00H                      | 00H                      | ● | ● | - |
|      | Digital function | X (Refer to table 4.1.2) | X (Refer to table 4.1.2) | ● | ● | - |
| P120 | GPIO             | 00H                      | 00H                      | ● | ● | ● |
|      | ANI14            | 00H                      | 00H                      | ● | ● | ● |
|      | VCOUT0           | 00H                      | 00H                      | ● | ● | ● |
|      | Digital function | X (Refer to table 4.1.2) | X (Refer to table 4.1.2) | ● | ● | ● |
| P121 | GPIO             | 00H                      | 00H                      | ● | ● | ● |
|      | X1               | 00H                      | 00H                      | ● | ● | ● |
|      | Digital function | X (Refer to table 4.1.2) | X (Refer to table 4.1.2) | ● | ● | ● |
| P122 | GPIO             | 00H                      | 00H                      | ● | ● | ● |
|      | X2               | 00H                      | 00H                      | ● | ● | ● |
|      | EXCLK            | 00H                      | 00H                      | ● | ● | ● |
|      | Digital function | X (Refer to table 4.1.2) | X (Refer to table 4.1.2) | ● | ● | ● |
| P123 | GPIO             | 00H                      | 00H                      | ● | ● | - |
|      | XT1              | 00H                      | 00H                      | ● | ● | - |
|      | Digital function | X (Refer to table 4.1.2) | X (Refer to table 4.1.2) | ● | ● | - |
| P124 | GPIO             | 00H                      | 00H                      | ● | ● | - |
|      | XT2              | 00H                      | 00H                      | ● | ● | - |
|      | EXCLKS           | 00H                      | 00H                      | ● | ● | - |
|      | Digital function | X (Refer to table 4.1.2) | X (Refer to table 4.1.2) | ● | ● | - |
| P130 | GPIO             | 00H                      | 00H                      | ● | - | - |
|      | ANI35            | 00H                      | 00H                      | ● | - | - |
|      | Digital function | X (Refer to table 4.1.2) | X (Refer to table 4.1.2) | ● | - | - |
| P136 | GPIO             | 00H                      | 00H                      | ● | ● | ● |
|      | ANI36            | 00H                      | 00H                      | ● | ● | ● |
|      | INTP0            | 00H                      | 00H                      | ● | ● | ● |
|      | Digital function | X (Refer to table 4.1.2) | X (Refer to table 4.1.2) | ● | ● | ● |
| P137 | GPIO             | 00H                      | 00H                      | ● | ● | ● |
|      | SWCLK            | 00H                      | 00H                      | ● | ● | ● |
|      | Digital function | X (Refer to table 4.1.2) | X (Refer to table 4.1.2) | ● | ● | ● |
| P140 | GPIO             | 00H                      | 00H                      | ● | ● | - |
|      | Digital function | X (Refer to table 4.1.2) | X (Refer to table 4.1.2) | ● | ● | - |
| P146 | GPIO             | 00H                      | 00H                      | ● | - | - |
|      | ANI15            | 00H                      | 00H                      | ● | - | - |
|      | Digital function | X (Refer to table 4.1.2) | X (Refer to table 4.1.2) | ● | - | - |
| P147 | GPIO             | 00H                      | 00H                      | ● | ● | ● |
|      | ANI12            | 00H                      | 00H                      | ● | ● | ● |
|      | VREF0            | 00H                      | 00H                      | ● | ● | ● |
|      | Digital function | X (Refer to table 4.1.2) | X (Refer to table 4.1.2) | ● | ● | ● |
| VDD  | Power            | -                        | -                        | ● | ● | ● |
| VSS  | Ground           | -                        | -                        | ● | ● | ● |



All ports of this product are divided into 3 types, namely type 1 to type 3. The corresponding conditions are as follows:

Type 1: bidirectional I / O function

Type 2: only input function, such as clock, corresponding pins p121-p124

Type 3: reset function, corresponding to pin resetb

Refer to 4.3 port type for the block diagram of each type of pin

Table 4.1.2 Table of Digital function configuration (1/2 output functions)

| Port Name | Configuration register   | Setting value | Digital functions |
|-----------|--------------------------|---------------|-------------------|
| P00~P147  | P00cfg[3:0]~P147cfg[3:0] | 4'h00         | Default function  |
|           |                          | 4'h01         | TO10              |
|           |                          | 4'h02         | TO11              |
|           |                          | 4'h03         | TO12              |
|           |                          | 4'h04         | TO13              |
|           |                          | 4'h05         | SDO00/TxD0        |
|           |                          | 4'h06         | SDO20/TxD2        |
|           |                          | 4'h07         | CLKBUZ0           |
|           |                          | 4'h08         | SCLKO00           |
|           |                          | 4'h09         | SCLKO20           |
|           |                          | 4'h0a         | TxD1              |

**Note:** P60 and p61 are nod outputs, which should be noted during configuration and use.

Table 4.1.2 Table of Digital function configuration (2/2 input functions)

| Configuration register   | Setting value | Digital functions              |
|--------------------------|---------------|--------------------------------|
| TI10PCFG                 | 6'h00         | Default input function         |
| TI11PCFG                 | 6'h01         | P00 selected as input function |
| TI12PCFG                 | 6'h02         | P01 selected as input function |
| TI13PCFG                 | 6'h03         | P10 selected as input function |
| INTP0PCFG                | 6'h04         | P11 selected as input function |
| INTP1PCFG                | 6'h05         | P12 selected as input function |
| INTP2PCFG                | 6'h06         | P13 selected as input function |
| INTP3PCFG                | 6'h07         | P14 selected as input function |
| SDI00PCFG (SPI/IIC/UART) | 6'h08         | P15 selected as input function |
| SCLKI00PCFG (SPI/IIC)    | 6'h09         | P16 selected as input function |
| SS00PCFG (SPI)           | 6'h0a         | P17 selected as input function |
| SDI20PCFG (SPI/UART)     | 6'h0b         | P20 selected as input function |
| SCLKI20PCFG (SPI)        | 6'h0c         | P21 selected as input function |
| RXD1PCFG (UART)          | 6'h0d         | P22 selected as input function |
| SDAA0PCFG                | 6'h0e         | P23 selected as input function |
| SCLA0PCFG                | 6'h0f         | P24 selected as input function |
|                          | 6'h10         | P25 selected as input function |
|                          | 6'h11         | P26 selected as input function |
|                          | 6'h12         | P27 selected as input function |

|       |                                 |
|-------|---------------------------------|
| 6'h13 | P30 selected as input function  |
| 6'h14 | P31 selected as input function  |
| 6'h15 | P40 selected as input function  |
| 6'h16 | P41 selected as input function  |
| 6'h17 | P50 selected as input function  |
| 6'h18 | P51 selected as input function  |
| 6'h19 | P60 selected as input function  |
| 6'h1a | P61 selected as input function  |
| 6'h1b | P62 selected as input function  |
| 6'h1c | P63 selected as input function  |
| 6'h1d | P70 selected as input function  |
| 6'h1e | P71 selected as input function  |
| 6'h1f | P72 selected as input function  |
| 6'h20 | P73 selected as input function  |
| 6'h21 | P74 selected as input function  |
| 6'h22 | P75 selected as input function  |
| 6'h23 | P120 selected as input function |
| 6'h24 | P121 selected as input function |
| 6'h25 | P122 selected as input function |
| 6'h26 | P123 selected as input function |
| 6'h27 | P124 selected as input function |
| 6'h28 | P130 selected as input function |
| 6'h29 | P136 selected as input function |
| 6'h2a | P136 selected as input function |
| 6'h2b | P140 selected as input function |
| 6'h2c | P146 selected as input function |
| 6'h2d | P147 selected as input function |

Table 4.1.3 SPI pin function configuration register

| Register name | Setting value | SPI pin function        |        |         |         |
|---------------|---------------|-------------------------|--------|---------|---------|
|               |               | SPINSS                  | SPISCK | SPIMISO | SPIMOSI |
| SPIP_CFG[1:0] | 2'b00         | Not assigned to any pin |        |         |         |
|               | 2'b01         | P50                     | P51    | P17     | P16     |
|               | 2'b10         | P63                     | P31    | P75     | P74     |
|               | 1'b11         | P25                     | P24    | P23     | P22     |

## 4.2 Pins Other Than Port Pins

(1/2)

| Function Name                                  | I/O | Function  |
|--|-----|---|
| ANI0~ANI36                                     | I   | A/D converter analog input  |
| INTP0~INTP3                                    | I   | External interrupt request input pin for which the valid edge (rising edge, falling edge, or both rising and falling edges) can |
| VCIN0  | I   | Comparator 0 analog voltage input   |
| VCIN10, VCIN11, VCIN12, VCIN13                 | I   | Comparator 1 analog voltage input/reference voltage input   |
| VREF0  | I   | Comparator 0 reference voltage input  |
| VCOUT0, VCOUT1                                 | O   | Comparator output   |
| PGA0IN, PGA1IN                                 | I   | PGA voltage input   |
| PGA0GND, PGA1GND                               | I   | PGA reference voltage input   |
| KR0 ~KR5                                       | I   | Key interrupt input   |
| CLKBUZ0, CLKBUZ1                               | O   | Clock output/buzzer output  |
| RTC1HZ   | O   | Real-time clock correction clock (1 Hz) output  |
| RESETB   | I   | This is the active-low system reset input pin. If it is not used, connect this pin to VDD through a resistor or directly.       |
| IrRxD  | I   | IrDA receive data   |
| IrTxD  | O   | IrDA transmit data  |
| RxD0~RxD2                                      | I   | Serial data input pins of serial interface UART0 to UART2   |
| TxD0~TxD2                                      | O   | Serial data output pins of serial interface UART0 to UART2  |
| SCL00, SCL01, SCL10, SCL11, SCL20, SCL21       | I/O | Serial clock I/O pins of serial interface IIC00, IIC01, IIC10, IIC11, IIC20 and IIC21   |
| SDA00, SDA01, SDA10, SDA11, SDA20, SDA21       | I/O | Serial data I/O pins of serial interface IIC00, IIC01, IIC10, IIC11, IIC20 and IIC21  |
| SCLK00, SCLK01, SCLK10, SCLK11, SCLK20, SCLK21 | I/O | Serial clock I/O pins of serial interface SSPI00, SSPI01, SSPI10, SSPI11, SSPI20, and SSPI21                                    |
| SDI00, SDI01, SDI10, SDI11, SDI20, SDI21       | I   | Serial data input pins of serial interface SSPI00, SSPI01, SSPI10, SSPI11, SSPI20, and SSPI21                                   |

(2/2)

| Function Name                               | I/O | Function  |
|---|-----|---|
| SS00  | I   | Chip select input pin of serial interface SSPI00  |
| SDO00, SDO01, SDO10,<br>SDO11, SDO20, SDO21 | O   | Serial data output pins of serial interface SSPI00,<br>SSPI01, SSPI10, SSPI11, SSPI20, and SSPI21 |
| SCLA0                                       | I/O | Serial clock I/O pins of serial interface IICA0   |
| SDAA0                                       | I/O | Serial data I/O pins of serial interface IICA0  |
| SPINSS                                      | I   | Chip select input pin of serial interface SPI   |
| SPISCK                                      | I/O | Serial clock I/O pins of serial interface SPI   |
| SPIMISO                                     | I/O | Serial data input/output pins of serial interface SPI   |
| SPI MOSI                                    | I/O | Serial data input/output pins of serial interface SPI   |
| TI00~TI03                                   | I   | The pins for inputting an external count clock/capture trigger                                    |
| TO00~TO03                                   | O   | Timer output pins of 16-bit Timer4  |
| TI10~TI13                                   | I   | The pins for inputting an external count clock/capture trigger                                    |
| TO10~TO13                                   | O   | Timer output pins of 16-bit Timer4  |
| X1, X2                                      | -   | Resonator connection for main system clock  |
| EXCLK                                       | I   | External clock input for main system clock  |
| XT1, XT2                                    | -   | Resonator connection for subsystem clock  |
| EXCLKS                                      | I   | External clock input for subsystem clock  |
| VDD   | -   | Positive power supply   |
| AVREFP                                      | I   | A/D converter reference potential (+ side) input  |
| AVREFM                                      | I   | A/D converter reference potential (- side) input  |
| VSS   | -   | Ground  |
| SWDIO                                       | I/O | SWD data line   |
| SWCLK                                       | I   | SWD clock line  |

Remark: Use bypass capacitors (about 0.1 uF) as noise and latch up countermeasures with relatively thick wires at the shortest distance to VDD to VSS lines.

## 5 Functional Overview

### 5.1 ARM® Cortex®-M0+ Core with MPU

Cortex-M0(+) processor is a new generation of ARM processors for embedded systems. It provides a low-cost platform for low pin count and low power consumption microcontrollers, while providing excellent computing performance and advanced system response to interrupts.

The 32-bit RISC processor of the Cortex-M0(+) processor provides excellent code efficiency and provides high-performance expectations of the ARM core, which is different from 8-bit and 16-bit devices of the same memory size. The Cortex-M0(+) processor has 32 address lines and a storage space of up to 4G.

BAT32G135 uses an embedded ARM core, so it is compatible with all ARM tools and software.

### 5.2 Memory

#### 5.2.1 Flash

The MCU provides an on-chip flash memory support to program, erase and rewrite. Functions is shown in below:

- 64KB Flash Memory (program/data flash).
- 1.5 KB Special data flash memory
- Support sector erase, sector size is 512byte, erase time 4ms
- Support byte/half-word/word (32bit) programming, programming time 24us

#### 5.2.2 SRAM

The MCU provides an on-chip high-speed SRAM module of 8KB with either parity-bit checking.

### 5.3 DMA

The built-in DMA (Direct Memory Access) controller can realize the function of data transfer between memories without using the CPU.

- Support the start of DMA through the interruption of peripheral functions, which can realize real-time control through communication, timer and A/D.
- Transfer space: 4 GB area from 0000 0000h to FFFF FFFFh except reserved areas.
- Support 4 transfer modes (normal transfer mode, repeat transfer mode, block transfer mode and chain transfer mode).

## 5.4 Event Link Controller (EVENTC)

The Event Link Controller (EVENTC) uses the event requests generated by various peripheral modules as source signals to connect them to different modules, allowing direct link between the modules without CPU intervention.

The EVENTC has the following functions:

- Capable of directly linking event signals from 15 types of peripheral functions to specified peripheral functions.
- Event signals can be used as activation sources for operating any one of 3 types of peripheral functions.

## 5.5 Clock Generator

The clock generator generates the clock to be supplied to the CPU and peripheral hardware.

The following three kinds of system clocks and clock oscillators are selectable.

### 5.5.1 Main System Clock

- X1 oscillator:  
This circuit oscillates a clock of  $f_X = 1$  to 20 MHz by connecting a resonator to X1 pin and X2 pin. Oscillation can be stopped by executing the DEEPSLEEP instruction or setting of the MSTOP bit.
- High-speed on-chip oscillator (High-speed OCO):  
The frequency at which to oscillate can be selected from among  $f_{HOCO} = 64, 48, 32, 24, 16, 12, 8, 6, 4, 3, 2,$  or 1 MHz (TYP.) by using the option byte. After a reset release, the CPU always starts operating with this high-speed on-chip oscillator clock. Oscillation can be stopped by executing the DEEPSLEEP instruction or setting of the HIOSTOP bit. The frequency specified by using an option byte can be changed by using the high-speed on-chip oscillator frequency select register (HOCODIV).
- X2 external main system clock:  
An external main system clock ( $f_{EX} = 1$  to 20 MHz) can also be supplied from the EXCLK/X2/P122 pin. An external main system clock input can be disabled by executing the STOP instruction or setting of the MSTOP bit.

## 5.5.2 Subsystem Clock

- XT1 clock oscillator:  
This circuit oscillates a clock of  $f_{XT} = 32.768$  KHz by connecting a 32.768 KHz resonator to XT1 pin and XT2 pin. Oscillation can be stopped by setting the XTSTOP bit.
- XT2 external subsystem clock:  
An external subsystem clock ( $f_{EXS} = 32.768$  KHz) can also be supplied from the EXCLKS/XT2/P124 pin. An external subsystem clock input can be disabled by the setting of the XTSTOP bit.

## 5.5.3 Low-speed On-chip Oscillator

- Low-speed on-chip oscillator (Low-speed OCO):  
This circuit oscillates a clock of  $f_{IL} = 15$  KHz (TYP.).  
The low-speed on-chip oscillator clock cannot be used as the CPU clock.  
Only the following peripheral hardware runs on the low-speed on-chip oscillator clock.
  - Watchdog timer (WWDT)
  - Real-time clock (RTC)
  - 15-bit interval timer

## 5.6 Power Management

### 5.6.1 Power Supply

VDD: External power, voltage range 1.8 to 5.5V

### 5.6.2 Power-on-reset Circuit

The power-on-reset circuit (POR) has the following functions.

- Generates internal reset signal at power on. The reset signal is released when the supply voltage (VDD) exceeds the detection voltage (VPOR). Note that the reset state must be retained until the operating voltage becomes in the range defined of POR function. This can be achieved by utilizing the voltage detection circuit or controlling the externally input reset signal.
- Compares supply voltage (VDD) and detection voltage (VPDR), and then generates internal reset signal when  $VDD < VPDR$ . Note that, after power is supplied, this LSI should be placed in the DEEPSLEEP mode, or in the reset state by utilizing the voltage detector or externally input reset signal, before the operation voltage falls below the range defined of POR function. When restarting the operation, make sure that the operation voltage has returned within the range of operation.

### 5.6.3 Voltage Detector

The operation mode and detection voltages (VLVDH, VLVDL, VLVD) for the voltage detector is set by using the option byte. The voltage detector (LVD) has the following functions.

- The LVD circuit compares the supply voltage (VDD) with the detection voltage (VLVDH, VLVDL, VLVD), and generates an internal reset or internal interrupt signal.
- The detection level for the power supply detection voltage (VLVDH, VLVDL, VLVD) can be selected by using the option byte.
- Operable in DEEPSLEEP mode.
- When the power supply rises, before reaching the working voltage range, it must be kept in the reset state through the voltage detection circuit or external reset. When the power supply drops, it must be transferred to deep sleep mode before it is less than the operating voltage range, or set to the reset state by the voltage detection circuit or external reset.
- The range of operating voltage varies with the setting of the user option byte.

## 5.7 Low Power Modes

The product supports two low-power modes with short start-up time:

- **SLEEP Mode:** When a WFI instruction is executed while SBYCR.SSBY bit is 0, the MCU enters Sleep mode. In this mode, the CPU stops operating but the contents of its internal registers are retained. Other peripheral functions do not stop. Available resets or interrupts in Sleep mode cause the MCU to cancel Sleep mode.
- **DEEPSLEEP Mode:** When a WFI instruction is executed while SBYCR.SSBY bit is 1, the MCU enters Software Deepsleep mode. In this mode, the CPU, most of the on-chip peripheral functions and oscillators stop. However, the contents of the CPU internal registers and SRAM data, the states of on-chip peripheral functions and the I/O Ports are retained. Deepsleep mode allows a significant reduction in power consumption because most of the oscillators stop in this mode.

In either mode, the registers, flags, and data memory retain their contents before being set to standby mode, and also maintain the status of the output latch and output buffer of the input/output port.



## 5.8 Reset Function

The following seven operations are available to generate a reset signal.

- 1) External reset input via RESETB pin
- 2) Internal reset by watchdog timer program loop detection
- 3) Internal reset by comparison of supply voltage and detection voltage of power-on-reset (POR) circuit
- 4) Internal reset by comparison of supply voltage of the voltage detector (LVD) and detection voltage
- 5) Internal reset by RAM parity error
- 6) Internal reset by illegal-memory access
- 7) software reset

External and internal resets start program execution from the address at 0000H and 0001H when the reset signal is generated.

## 5.9 Interrupts

The Cortex-M0+ processor has a built-in Nested Vectored Interrupt Controller (NVIC) that supports up to 32 interrupt request (IRQ) inputs and one non-maskable interrupt (NMI) input. In addition, the processor supports multiple internal exceptions.

This product extends 32 maskable interrupt requests (IRQ) and 1 non-maskable interrupt (NMI), and can support up to 64 maskable interrupt sources and one non-maskable interrupt source. The actual number of interrupt sources varies by product.

## 5.10 Real-timer Clock (RTC)

The real-time clock has the following features.

- Counters of year, month, week, day, hour, minute, and second.
- Constant-period interrupt function (period: 0.5 seconds, 1 second, 1 minute, 1 hour, 1 day, 1 month)
- Alarm interrupt function (alarm: week, hour, minute)
- Pin output function of 1 Hz
- Support frequency division of sub-system clock or main system clock as RTC running clock
- Real-time clock interrupt signal (INTRTC) can be used to wake up in deep sleep mode
- Support a wide range of clock correction functions

Caution: The count of year, month, week, day, hour, minutes and second can only be performed when a subsystem clock ( $f_{SUB} = 32.768$  KHz) is selected as the operation clock of the real-time clock.

When the low-speed oscillation clock ( $f_{IL} = 15$  KHz/30KHz) is selected, only the constant-period Interrupt function is available.

## 5.11 Watchdog Timer

The counting operation of the watchdog timer is set by the option byte. The watchdog timer operates on the low-speed on-chip oscillator clock (f<sub>IL</sub> = 15 KHz). The watchdog timer is used to detect an inadvertent program loop. If a program loop is detected, an internal reset signal is generated.

Program loop is detected in the following cases:

- If the watchdog timer counter overflows
- If a 1-bit manipulation instruction is executed on the watchdog timer enable register (WDTE)
- If data other than “ACH” is written to the WDTE register
- If data is written to the WDTE register during a window close period

## 5.12 SysTick Timer

This timer is dedicated to real-time operating systems, but can also be used as a standard down counter.

Its characteristics are: when the 24-bit down counter self-loading capacity counter reaches 0, there is a shieldable system interruption.

## 5.13 Timer4

The timer4 has eight (two units of four) 16-bit timers. Each 16-bit timer is called a channel and can be used as an independent timer. In addition, two or more “channels” can be used to create a high-accuracy timer.

For details about each function, see the table below.

| Independent channel operation function   | Simultaneous channel operation function  |
|--|--|
| <ul style="list-style-type: none"> <li>● Interval timer</li> <li>● Square wave output</li> <li>● External event counter</li> <li>● Divider</li> <li>● Input pulse interval measurement</li> <li>● Measurement of high-/low-level width of input signal</li> <li>● Delay counter</li> </ul> | <ul style="list-style-type: none"> <li>● One-shot pulse output</li> <li>● PWM output</li> <li>● Multiple PWM output</li> </ul> |

## 5.13.1 Independent Channel Operation Function

By operating a channel independently, it can be used for the following purposes without being affected by the operation mode of other channels.

- 1) Interval timer: Each timer of the unit can be used as a reference timer that generates an interrupt (INTTM) at fixed intervals.
- 2) Square wave output: A toggle operation is performed each time INTTM<sub>mn</sub> interrupt is generated and a square wave with a duty factor of 50% is output from a timer output pin (TO).
- 3) External event counter: Each timer of the unit can be used as an event counter that generates an interrupt when the number of the valid edges of a signal input to the timer input pin (TI) has reached a specific value.
- 4) Divider function (channel 0 only): A clock input from a timer input pin (TI00) is divided and output from an output pin (TO00).
- 5) Input pulse interval measurement: Counting is started by the valid edge of a pulse signal input to a timer input pin (TI). The count value of the timer is captured at the valid edge of the next pulse. In this way, the interval of the input pulse can be measured.
- 6) Measurement of high-/low-level width of input signal: Counting is started by a single edge of the signal input to the timer input pin (TI), and the count value is captured at the other edge. In this way, the high-level or low-level width of the input signal can be measured.
- 7) Delay counter: Counting is started at the valid edge of the signal input to the timer input pin (TI), and an interrupt is generated after any delay period.

## 5.13.2 Simultaneous Channel Operation Function

By using the combination of a master channel (a reference timer mainly controlling the cycle) and slave channels (timers operating according to the master channel), channels can be used for the following purposes.

- 1) One-shot pulse output: Two channels are used as a set to generate a one-shot pulse with a specified output timing and a specified pulse width.
- 2) PWM (Pulse Width Modulation) output: Two channels are used as a set to generate a pulse with a specified period and a specified duty factor.
- 3) Multiple PWM (Pulse Width Modulation) output: By extending the PWM function and using one master channel and two or more slave channels, up to three types of PWM signals that have a specific period and a specified duty factor can be generated.

### 5.13.3 8-bit Timer Operation Function

The 8-bit timer operation function makes it possible to use a 16-bit timer channel in a configuration consisting of two 8-bit timer channels. This function can only be used for channels 1 and 3.

### 5.13.4 LIN-bus supporting function

Timer4 is used to check whether signals received in LIN-bus communication match the LIN-bus communication format.

- 1) Detection of wakeup signal: The timer starts counting at the falling edge of a signal input to the serial data input pin (RxD0) of UART0 and the count value of the timer is captured at the rising edge. In this way, a low-level width can be measured. If the low-level width is greater than a specific value, it is recognized as a wakeup signal.
- 2) Detection of break field: The timer starts counting at the falling edge of a signal input to the serial data input pin (RxD0) of UART0 after a wakeup signal is detected, and the count value of the timer is captured at the rising edge. In this way, a low-level width is measured. If the low-level width is greater than a specific value, it is recognized as a break field.
- 3) Measurement of pulse width of sync field: After a break field is detected, the low-level width and high-level width of the signal input to the serial data input pin (RxD0) of UART0 are measured. From the bit interval of the sync field measured in this way, a baud rate is calculated.

## 5.14 EPWM Output Control Function

Use Timer4's PWM output function to control one DC motor or two stepping motors. By truncating the source CMP0 output, INTP0 input and EVENTC event, the output can be truncated. Through the setting of the software, it is possible to choose from 4 types of output for Hi-Z output, low-level output, high-level output and forbidden cut-off output.

## 5.15 15-bit Interval Timer

An interrupt (INTIT) is generated at any previously specified time interval. It can be utilized for wakeup from DEEPSLEEP mode.

## 5.16 Clock Output/Buzzer Output Controller

The clock output controller is intended for clock output for supply to peripheral ICs. Buzzer output is a function to output a square wave of buzzer frequency.

## 5.17 Serial communication Interface (SCI)

This product has two serial array units. Serial array unit has four serial channels. All channels can achieve UART, simplified SPI (3-wire serial) and simplified I2C. Function assignment of each channel is as shown below.

### 5.17.1 3-wire Serial I/O (SSPI)

Data is transmitted or received in synchronization with the serial clock (SCK) output from the master channel. 3-wire serial communication is clocked communication performed by using three communication lines: one for the serial clock (SCK), one for transmitting serial data (SO), one for receiving serial data (SI).

[ Data transmission/reception]

- Data length of 7 or 8 bits
- Phase control of transmit/receive data
- MSB/LSB first selectable

[ Clock control ]

- Master/slave selection
- Phase control of I/O clock
- Setting of transfer period by prescaler and internal counter of each channel
- Maximum transfer rate

During master communication: Max.  $f_{CLK}/2$

During slave communication: Max.  $f_{MCK}/6$

[ Interrupt function ]

- Transfer end interrupt/buffer empty interrupt

[ Error detection flag ]

- Overrun error

## 5.17.2 4-wire Serial I/O with Slave Select Input Function

This is a clock synchronization using a slave chip select input (SSI), a serial clock (SCK), a transmit serial data (SO) and a receive serial data (SI) a total of 4 communication lines for communication Communication Interface.

[ Data transmission/reception]

- Data length of 7 or 8 bits
- Phase control of transmit/receive data
- MSB/LSB first selectable
- Level setting of transmit/receive data

[ Clock control ]

- Phase control of I/O clock
- Setting of transfer period by prescaler and internal counter of each channel
- Maximum transfer rate

During slave communication: Max.  $fMCK/6$

[ Interrupt function ]

- Transfer end interrupt/buffer empty interrupt

[ Error detection flag ]

- Overrun error

## 5.17.3 UART

This is a start-stop synchronization function using two lines: serial data transmission (TxD) and serial data reception (RxD) lines. By using these two communication lines, each data frame, which consist of start bit, data, parity bit and stop bit, is transferred asynchronously (using the internal baud rate) between the microcontroller and the other communication party. Full-duplex UART communication can be performed by using a channel dedicated to transmission (even-numbered channel) and a channel dedicated to reception (odd-numbered channel). The LIN-bus can be implemented by using UART0, Timer4 unit 0 (channel 3), and an external interrupt (INTP0).

[ Data transmission/reception ]

- Data length of 7, 8, or 9 bits
- Select the MSB/LSB first
- Level setting of transmit/receive data (selecting whether to reverse the level)
- Parity bit appending and parity check functions
- Stop bit appending, stop bit check function

[Interrupt function]

- Transfer end interrupt/buffer empty interrupt
- Error interrupt in case of framing error, parity error, or overrun error

[Error detection flag]

- Framing error, parity error, or overrun error

[ LIN-bus functions ]

- Wakeup signal detection
- Break field (BF) detection
- Sync field measurement, baud rate calculation

## 5.17.4 Simplified I<sup>2</sup>C

This is a clocked communication function to communicate with two or more devices by using two lines: serial clock (SCL) and serial data (SDA). This simplified I<sup>2</sup>C is designed for single communication with a device such as EEPROM, flash memory, or A/D converter, and therefore, it functions only as a master. Make sure by using software, as well as operating the control registers, that the AC specifications of the start and stop conditions are observed.

[ Data transmission/reception ]

- Master transmission, master reception (only for single master application)
- ACK output function and ACK detection function
- Data length of 8 bits (When an address is transmitted, the address is specified by the higher 7 bits, and the least significant bit is used for R/W control.)
- Manual generation of start condition and stop condition

[ Interrupt function ]

- Transfer end interrupt

[ Error detection flag ]

- ACK error or overrun error

[ Functions not supported by simplified I<sup>2</sup>C ]

- Slave transmission, slave reception
- Arbitration loss detection function
- Wait detection functions

## 5.18 Standard Serial Peripheral Interface SPI

The serial interface SPI has the following 2 modes.

- Operation stop mode:  
This mode is used when serial transfers are not performed. It can reduce power consumption.
- 3-wire serial I/O mode:  
This mode uses 3 lines of serial clock (SCK) and serial data bus (MISO and MOSI) to transmit 8-bit or 16-bit data with multiple devices.

## 5.19 Serial Interface IICA

Serial interface IICA has the following three modes.

- Operation stop mode:  
This mode is used when serial transfers are not performed. It can reduce power consumption.
- I2C bus mode (multi-master application supported):  
This mode is used for 8-bit data transfers with several devices via two lines: a serial clock (SCLAn) line and a serial data bus (SDAAn) line.  
It complies with the I2C bus format and the master device can generate “start condition”, “address”, “transfer direction specification”, “data”, and “stop condition” data to the slave device, via the serial data bus. The slave device automatically detects these received status and data by hardware. It can simplify the part of application program that controls the I2C bus. Since the SCLA and SDAA pins are used for open drain outputs, serial interface IICA requires pull-up resistors for the serial clock line and the serial data bus line.
- Wakeup mode:  
The DEEPSLEEP mode can be released by generating an interrupt request signal (INTIICA) when an extension code from the master device or a local address has been received while in DEEPSLEEP mode.



## 5.20 A/D Converter (ADC)

The A/D converter is a converter that converts analog input signals into digital values, and is configured to control analog inputs, including up to 35 channels of A/D converter analog inputs (ANI0 to ANI13, ANI16 to ANI36).

The A/D converter has the following function.

- 12-bit resolution A/D conversion, Conversionrate 1.42MSPS.
- Trigger mode: Software trigger, Hardware trigger mode
- Channel selection: Single channel select mode and Scan mode
- Conversion operation mode: One-shot conversion mode and Sequential conversion mode
- Operation voltage:  $1.8V \leq VDD \leq 5.5V$
- Can detect the internal reference voltage (1.45V) and temperature sensor.

Various A/D conversion modes can be specified by using the mode combinations below.

|                                   |  |  |
|-----------------------------------|--|--|
| Trigger mode                      | Software trigger                                   | Conversion is started by software.   |
|                                   | Hardware trigger no-wait mode                      | Conversion is started by detecting a hardware trigger.   |
|                                   | Hardware trigger wait mode                         | The power is turned on by detecting a hardware trigger while the system is off and in the conversion standby state, and conversion is then started automatically after the stabilization wait time passes. |
| Channel selection mode            | Select mode  | A/D conversion is performed on the analog input of one selected channel.   |
|                                   | Scan mode  | A/D conversion is performed on the analog input of four channels in order. Four consecutive channels can be selected from ANI0 to ANI15 as analog input channels.  |
| Conversion operation mode         | One-shot conversion mode                           | A/D conversion is performed on the selected channel once.  |
|                                   | Sequential conversion mode                         | A/D conversion is sequentially performed on the selected channels until it is stopped by software.   |
| Sampling time/<br>Conversion time | Sampling clock cycles /<br>Conversion clock cycles | The sampling time can be set by the register. The default value of the sampling clock is 13.5 clk, and the conversion clock number Min is 31.5 clk.  |

## 5.21 Programmable Gain Amplifier (PGA)

This product has two programmable gain amplifiers (PGA0, PGA1), The programmable gain amplifier is provided with the following functions.

- GAIN: X4, X8, X10, X12, X14, X16, X32
- The external pin(PGAGND) can be selected as the ground of the negative feedback resistance of the PGA (can be used as a differential mode)
- The output of PGA0 can be selected as the analog input for the A/D converter or the analog input of the positive terminal of comparator 0 (CMP0)
- PGA1 output can be selected as analog input for A/D converter

## 5.22 Comparator(CMP)

The product has two comparator channels. The comparator has the following functions.

- A pin selector switch is added to the analog input of CMP1.
- The external reference voltage input or internal reference voltage can be selected as the reference voltage.
- The canceling width of the noise canceling digital filter can be selected.
- An interrupt signal can be generated by detecting an active edge of the comparator output.
- An event link controller (EVENTC) event signal can be output by detecting an active edge of the comparator output.

## 5.23 Serial Wire Debug (SW-DP)

SW-DP interface allows connection to the microcontroller via serial line debugging tools.

## 5.24 Safety Functions

### 5.24.1 Flash Memory CRC Operation Function (High-speed CRC, General-purpose CRC)

This detects data errors in the flash memory by performing CRC operations.

Two CRC functions are provided according to the different applications.

- High-speed CRC: The CPU can be stopped and a high-speed check executed on its entire code flash memory area during the initialization routine.
- General CRC: This can be used for checking various data in addition to the code flash memory area while the CPU is running.

### 5.24.2 RAM Parity Error Detection Function

This detects parity errors when the RAM is read as data.

### 5.24.3 SFR Guard Function

This prevents SFRs (Special Function Register) from being rewritten when the CPU freezes.

### 5.24.4 Invalid Memory Access Detection Function

This detects illegal accesses to invalid memory areas.

### 5.24.5 Frequency Detection Function

This uses the timer4 to perform a self-check of the CPU/peripheral hardware clock frequency.

## 5.24.6 A/D Test Function

This is used to perform a self-check of A/D converter by performing A/D conversion on the positive internal reference voltage, negative reference voltage, analog input channel (ANI), temperature sensor output, and internal reference voltage output.

## 5.24.7 Digital Output Signal Level Detection Function

When the I/O pins are output mode, the output level of the pin can be read.

## 5.25 Key Function

A key interrupt (INTKR) can be generated by inputting a falling edge to the key interrupt input pins (KR0 to KR5).

# 6 Electrical Characteristics

## 6.1 Typical Application Peripheral Circuit

The connection reference of the MCU typical application peripheral circuit is as follows:

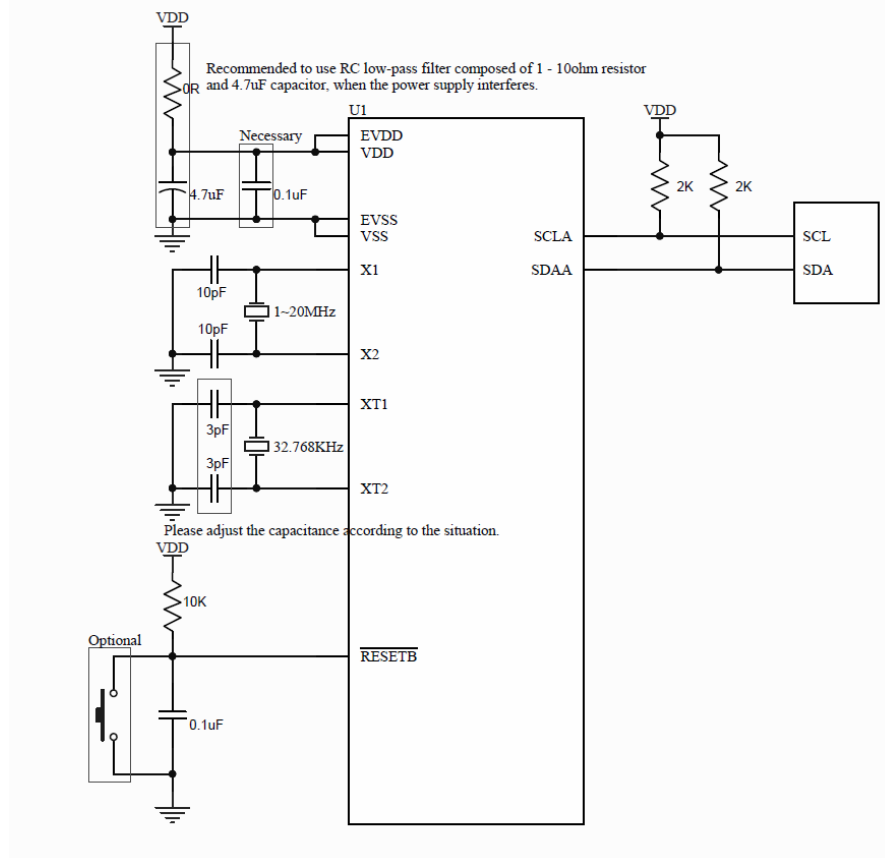

## 6.2 Absolute Maximum Voltage Ratings

( $T_A = -40 \sim +105^\circ\text{C}$ )

| Parameter            | Symbols | Conditions   | Ratings  | Unit |
|----------------------|---------|--|--|------|
| Supply voltage       | VDD     |  | -0.5~+6.5  | V    |
| Input voltage        | VI1     | P00~P01, P10~P17, P20~P27, P30~P31, P40~P41, P50~P51, P62~P63, P70~P75, P120~P124, P130, P136, P137, P140, P146, P147, EXCLK, EXCLKS, RESETB | -0.3~VDD+0.3 <sup>note1</sup>                                    | V    |
|                      | VI2     | P60~P61(N channel drain open circuit)  | - 0.3~+6.5   | V    |
| Output voltage       | VO      | P00~P01, P10~P17, P20~P27, P30~P31, P40~P41, P50~P51, P60~P63, P70~P75, P120, P130, P136, P137, P140, P146, P147                             | -0.3~VDD+0.3 <sup>note1</sup>                                    | V    |
| Analog input voltage | VAI     | ANI0~ANI24, ANI27~ANI36  | -0.3~VDD+0.3 and<br>-0.3~AVREF(+)+0.3<br><small>note1, 2</small> | V    |

note:

1. Must be 6.5 V or lower.
2. Do not exceed AVREF (+) + 0.3 V in case of A/D conversion target pin.

Caution:

Product quality may suffer if the absolute maximum rating is exceeded even momentarily for any parameter. That is, the absolute maximum ratings are rated values at which the product is on the verge of suffering physical damage, and therefore the product must be used under conditions that ensure that the absolute maximum ratings are not exceeded.

Remark:

1. Unless specified otherwise, the characteristics of alternate-function pins are the same as those of the port pins.
2. AVREF (+): + side reference voltage of the A/D converter.
3. VSS: Reference voltage

## 6.3 Absolute Maximum Current Ratings

( $T_A = -40 \sim +105^\circ\text{C}$ )

| Parameter                     | Symbols                          | Conditions        |  | Ratings  | Unit     |
|-------------------------------|----------------------------------|-------------------|--|--|----------|
| Output current, high          | IOH1                             | Per pin           | P00~P01, P10~P17, P20~P27, P30~P31, P40~P41, P50~P51, P62~P63, P70~P75, P130, P136, P137, P140, P146, P147 | -40  | mA       |
|                               |                                  | Total of all pins | P00~P01, P20~P27, P40~P41, P120, P130, P136, P137, P140  | -70  | mA       |
|                               |                                  |                   | P10~P17, P30~P31, P50~P51, P62~P63, P70~P75, P146, P147  | -100   | mA       |
|                               | IOH2                             | Per pin           | P121~P124  | -3   | mA       |
|                               |                                  | Total of all pins |  | -15  | mA       |
|                               | Output current, low              | IOL1              | Per pin  | P00~P01, P10~P17, P20~P27, P30~P31, P40~P41, P50~P51, P60~P63, P70~P75, P120, P130, P136, P137, P140, P146, P147 | 40       |
| Total of all pins             |                                  |                   | P00~P01, P20~P27, P40~P41, P120, P130, P136, P137, P140  | 100  | mA       |
|                               |                                  |                   | P10~P17, P30~P31, P50~P51, P60~P63, P70~P75, P146, P147  | 120  | mA       |
| IOL2                          |                                  | Per pin           | P121~P124  | 15   | mA       |
|                               |                                  | Total of all pins |  | 45   | mA       |
| Operating ambient temperature |                                  | TA                | In normal operation mode   |  | -40~+105 |
|                               | In flash memory programming mode |                   |  |  |          |
| Storage temperature           | Tstg                             |                   |  | -65~+150   | °C       |

### Caution:

Product quality may suffer if the absolute maximum rating is exceeded even momentarily for any parameter. That is, the absolute maximum ratings are rated values at which the product is on the verge of suffering physical damage, and therefore the product must be used under conditions that ensure that the absolute maximum ratings are not exceeded.

### Remark:

Unless specified otherwise, the characteristics of alternate-function pins are the same as those of the port pins.

## 6.4 Oscillator Characteristics

### 6.4.1 X1, XT1 Characteristics

(TA=-40~+105°C, 1.8V≤VDD≤5.5V, VSS=0V)

| Resonator                                | Resonator                               | Conditions        | MIN | TYP    | MAX  | Unit |
|--|---|-------------------|-----|--------|------|------|
| X1 clock oscillation frequency (fX)      | Ceramic resonator/<br>crystal resonator |                   | 1.0 | -      | 20.0 | MHz  |
| X1 clock oscillation stabilization time  | Ceramic resonator/<br>crystal resonator | 20MHz, C=10pF     |     | 15     |      | ms   |
| X1 clock oscillation feedback resistor   | Ceramic resonator/<br>crystal resonator |                   | 0.6 |        | 1.8  | MΩ   |
| XT1 clock oscillation frequency (fXT)    | Crystal resonator                       |                   | 32  | 32.768 | 35   | KHz  |
| XT1 clock oscillation stabilization time | Crystal resonator                       | 32.768KHz, C=20pF |     | 2      |      | s    |

Note:

Indicates only permissible oscillator frequency ranges. Refer to AC Characteristics for instruction execution time.

Request evaluation by the manufacturer of the oscillator circuit mounted on a board to check the oscillator characteristics.

### 6.4.2 On-chip Oscillator Characteristics

(TA=-40~+105°C, 1.8V≤VDD≤5.5V, VSS=0V)

| Oscillators  | Conditions     | MIN                   | TYP | MAX                   | Unit |
|--|----------------|-----------------------|-----|-----------------------|------|
| High-speed on-chip oscillator clock frequency(f <sub>H</sub> )<br>Notes 1, 2 |                | 1.0                   |     | 64.0                  | MHz  |
| High-speed on-chip oscillator stabilization time(t <sub>SU</sub> )           |                |                       | 12  |                       | us   |
| High-speed on-chip oscillator clock frequency accuracy                       | TA= 10~+105°C  | -1.0                  |     | +1.0                  | %    |
|  | TA= -10~+105°C | -1.5 <sup>Note3</sup> |     | -1.5 <sup>Note3</sup> | %    |
|  | TA=-40~+105°C  | -4.0 <sup>Note3</sup> |     | -4.0 <sup>Note3</sup> | %    |
| Low-speed on-chip oscillator clock frequency(f <sub>L</sub> )                |                | 10                    | 15  | 20                    | KHz  |

Note:

1. High-speed on-chip oscillator frequency is selected with the option byte and HOCODIV register.
2. This only indicates the oscillator characteristics. Refer to AC Characteristics for instruction execution time.
3. The low temperature specification value is guaranteed by the design, and the low temperature condition is not measured for mass production.



## 6.5 DC Characteristics

### 6.5.1 Pin Characteristics

( $T_A = -40 \sim +105^\circ\text{C}$ ,  $1.8\text{V} \leq \text{VDD} \leq 5.5\text{V}$ ,  $\text{VSS} = 0\text{V}$ )

| Items                                  | Symbol | Conditions   | MIN  | TYP  | MAX | Unit                  |                       |    |
|--|--------|--|--|--|-----|-----------------------|-----------------------|----|
| Output current, high <sup>Note 1</sup> | IOH1   | Per pin for P00~P01、P10~P17、P20~P27、P30~P31、P40~P41、P50~P51、P62~P63、P70~P75、P120、P130、P136、P137、P140、P146、P147 | $1.8\text{V} \leq \text{VDD} \leq 5.5\text{V}$<br>$-40 \sim +85^\circ\text{C}$ |  |     | -                     | mA                    |    |
|  |        |  | $1.8\text{V} \leq \text{VDD} \leq 5.5\text{V}$<br>$85 \sim +105^\circ\text{C}$ |  |     | -6.0 <sup>Note2</sup> |                       |    |
|  |        | Total of P00~P01、P20~P27、P40~P41、P120、P130、P136、P137、P140<br>(When duty $\leq 70\%$ <sup>Note 3</sup> )        | $4.0\text{V} \leq \text{VDD} \leq 5.5\text{V}$<br>$-40 \sim +85^\circ\text{C}$ |  |     | -60.0                 | mA                    |    |
|  |        |  | $4.0\text{V} \leq \text{VDD} \leq 5.5\text{V}$<br>$85 \sim +105^\circ\text{C}$ |  |     | -30.0                 |                       |    |
|  |        |  | $2.4\text{V} \leq \text{VDD} < 4.0\text{V}$                                    |  |     | -12.0                 | mA                    |    |
|  |        |  | $1.8\text{V} \leq \text{VDD} < 2.4\text{V}$                                    |  |     | -6.0                  | mA                    |    |
|  |        | Per pin for P10~P17、P30~P31、P50~P51、P62~P63、P70~P75、P146、P147<br>(When duty $\leq 70\%$ <sup>Note 3</sup> )    | $4.0\text{V} \leq \text{VDD} \leq 5.5\text{V}$<br>$-40 \sim +85^\circ\text{C}$ |  |     | -80.0                 | mA                    |    |
|  |        |  | $4.0\text{V} \leq \text{VDD} \leq 5.5\text{V}$<br>$85 \sim +105^\circ\text{C}$ |  |     | -30.0                 |                       |    |
|  |        |  | $2.4\text{V} \leq \text{VDD} < 4.0\text{V}$                                    |  |     | -20.0                 | mA                    |    |
|  |        |  | $1.8\text{V} \leq \text{VDD} < 2.4\text{V}$                                    |  |     | -10.0                 | mA                    |    |
|  |        | Total<br>(When duty $\leq 70\%$ <sup>Note 3</sup> )  | $1.8\text{V} \leq \text{VDD} \leq 5.5\text{V}$<br>$-40 \sim +85^\circ\text{C}$ |  |     | -140.0                | mA                    |    |
|  |        |  | $1.8\text{V} \leq \text{VDD} \leq 5.5\text{V}$<br>$85 \sim +105^\circ\text{C}$ |  |     | -60.0                 | mA                    |    |
|  |        | IOH2   | Per pin for P121 ~ P124  | $1.8\text{V} \leq \text{VDD} \leq 5.5\text{V}$ |     |                       | -2.5 <sup>note2</sup> | mA |
|  |        |  | Total of P121 ~ P124<br>(When duty $\leq 70\%$ <sup>Note 3</sup> )             | $1.8\text{V} \leq \text{VDD} \leq 5.5\text{V}$ |     |                       | -10                   | mA |

Note:

- Value of current at which the device operation is guaranteed even if the current flows from the VDD pins to an output pin.
- Do not exceed the total current value.
- Specification under conditions where the duty factor  $\leq 70\%$ .  
The output current value that has changed to the duty factor  $> 70\%$  the duty ratio can be calculated with the following expression (when changing the duty factor from 70% to n%).

• Total output current of pins =  $(\text{IOH} \times 0.7) / (n \times 0.01)$

<Example> Where  $n = 80\%$  and  $\text{IOH} = -10.0 \text{ mA}$

Total output current of pins =  $(-10.0 \times 0.7) / (80 \times 0.01) \approx -8.7 \text{ mA}$

However, the current that is allowed to flow into one pin does not vary depending on the duty factor.

A current higher than the absolute maximum rating must not flow into one pin.

Remark: Unless specified otherwise, the characteristics of alternate-function pins are the same as those of the port pins.

( $T_A = -40 \sim +105^\circ\text{C}$ ,  $1.8\text{V} \leq \text{VDD} \leq 5.5\text{V}$ ,  $\text{VSS} = 0\text{V}$ )

| Items                                 | Symbol | Conditions   | MIN  | TYP  | MAX | Unit                |                     |    |
|---------------------------------------|--------|--|--|--|-----|---------------------|---------------------|----|
| Output current, low <sup>Note 1</sup> | IOH1   | Per pin for P00~P01、P10~P17、P20~P27、P30~P31、P40~P41、P50~P51、P60~P63、P70~P75、P120、P130、P136、P137、P140、P146、P147 | $1.8\text{V} \leq \text{VDD} \leq 5.5\text{V}$<br>$-40 \sim +85^\circ\text{C}$ |  |     | 35 <sup>note2</sup> | mA                  |    |
|                                       |        |  | $1.8\text{V} \leq \text{VDD} \leq 5.5\text{V}$<br>$85 \sim +105^\circ\text{C}$ |  |     | 20 <sup>note2</sup> |                     |    |
|                                       |        | Total of P00~P01、P20~P27、P40~P41、P120、P130、P136、P137、P140<br>(When duty $\leq 70\%$ <sup>Note 3</sup> )        | $4.0\text{V} \leq \text{VDD} \leq 5.5\text{V}$<br>$-40 \sim +85^\circ\text{C}$ |  |     | 100                 | mA                  |    |
|                                       |        |  | $4.0\text{V} \leq \text{VDD} \leq 5.5\text{V}$<br>$85 \sim +105^\circ\text{C}$ |  |     | 70                  |                     |    |
|                                       |        |  | $2.4\text{V} \leq \text{VDD} < 4.0\text{V}$                                    |  |     | 30                  | mA                  |    |
|                                       |        |  | $1.8\text{V} \leq \text{VDD} < 2.4\text{V}$                                    |  |     | 15                  | mA                  |    |
|                                       |        | Per pin for P10~P17、P30~P31、P50~P51、P60~P63、P70~P75、P146、P147<br>(When duty $\leq 70\%$ <sup>Note 3</sup> )    | $4.0\text{V} \leq \text{VDD} \leq 5.5\text{V}$<br>$-40 \sim +85^\circ\text{C}$ |  |     | 120                 | mA                  |    |
|                                       |        |  | $4.0\text{V} \leq \text{VDD} \leq 5.5\text{V}$<br>$85 \sim +105^\circ\text{C}$ |  |     | 80                  |                     |    |
|                                       |        |  | $2.4\text{V} \leq \text{VDD} < 4.0\text{V}$                                    |  |     | 40                  | mA                  |    |
|                                       |        |  | $1.8\text{V} \leq \text{VDD} < 2.4\text{V}$                                    |  |     | 20                  | mA                  |    |
|                                       |        | Total<br>(When duty $\leq 70\%$ <sup>Note 3</sup> )  | $1.8\text{V} \leq \text{VDD} \leq 5.5\text{V}$<br>$-40 \sim +85^\circ\text{C}$ |  |     | 150                 | mA                  |    |
|                                       |        |  | $1.8\text{V} \leq \text{VDD} \leq 5.5\text{V}$<br>$85 \sim +105^\circ\text{C}$ |  |     | 100                 |                     |    |
|                                       |        | IOH2   | Per pin for P121 ~ P124  | $1.8\text{V} \leq \text{VDD} \leq 5.5\text{V}$ |     |                     | 10 <sup>note2</sup> | mA |
|                                       |        |  | Total of P121 ~ P124<br>(When duty $\leq 70\%$ <sup>Note 3</sup> )             | $1.8\text{V} \leq \text{VDD} \leq 5.5\text{V}$ |     |                     | 40                  | mA |

Note:

- Value of current at which the device operation is guaranteed even if the current flows from an output pin to the VSS pins.
- Do not exceed the total current value.
- Specification under conditions where the duty factor  $\leq 70\%$ .

The output current value that has changed to the duty factor  $> 70\%$  the duty ratio can be calculated with the following expression (when changing the duty factor from 70% to n%).

$$\bullet \text{ Total output current of pins} = (\text{IOL} \times 0.7) / (n \times 0.01)$$

<Example> Where  $n = 80\%$  and  $\text{IOL} = 10.0 \text{ mA}$

$$\text{Total output current of pins} = (10.0 \times 0.7) / (80 \times 0.01) \approx 8.7 \text{ mA}$$

However, the current that is allowed to flow into one pin does not vary depending on the duty factor.

A current higher than the absolute maximum rating must not flow into one pin.

Remark: Unless specified otherwise, the characteristics of alternate-function pins are the same as those of the port pins.

( $T_A = -40 \sim +105^\circ\text{C}$ ,  $1.8\text{V} \leq V_{DD} \leq 5.5\text{V}$ ,  $V_{SS} = 0\text{V}$ )

| Items                             | Symbol      | Conditions  | MIN                     | TYP    | MAX    | Unit |
|-----------------------------------|-------------|---|-------------------------|--------|--------|------|
| Power input voltage               | VDD<br>EVDD |   | 1.8                     |        | 5.5    | V    |
| Power supply ground input voltage | VSS<br>EVSS |   | -0.3                    |        |        | V    |
| Input voltage, high               | VIH1        | P00~P01、P10~P17、P20~P27、<br>P30~P31、P40~P41、P50~P51、<br>P62~P63、P70~P75、P120~P124、<br>EXCLK、EXCLKS、RESETB、P130、<br>P136、P137、P140、P146、P147 | Schmitt input<br>0.8VDD |        | VDD    | V    |
|                                   | VIH2        | P60~P61   |                         | 0.7VDD | 6.0    |      |
| Input voltage, low                | VIL1        | P00~P01、P10~P17、P20~P27、<br>P30~P31、P40~P41、P50~P51、<br>P62~P63、P70~P75、P120~P124、<br>EXCLK、EXCLKS、RESETB、P130、<br>P136、P137、P140、P146、P147 | Schmitt input<br>0      |        | 0.2VDD | V    |
|                                   | VIL2        | P60~P61   |                         | 0      | 0.3VDD | V    |

Remark: Unless specified otherwise, the characteristics of alternate-function pins are the same as those of the port pins.

(TA=-40 ~ +105°C, 1.8V≤EVDD=VDD≤5.5V, VSS=Evss=0V)

| Items                | Symbol | Conditions   | MIN                         | TYP     | MAX | Unit |
|----------------------|--------|--|-----------------------------|---------|-----|------|
| Output voltage, high | VOH1   | P00~P01, P10~P17, P20~P27, P30~P31, P40~P41, P50~P51, P62~P63, P70~P75, P120, P130, P136, P137, P140, P146, P147 | 4.0V≤VDD≤5.5V, IOH1=-12.0mA | VDD-1.5 |     | V    |
|                      |        |  | 4.0V≤VDD≤5.5V, IOH1=-6.0mA  | VDD-0.7 |     | V    |
|                      |        |  | 2.4V≤VDD≤5.5V, IOH1=-3.0mA  | VDD-0.6 |     | V    |
|                      |        |  | 1.8V≤VDD≤5.5V, IOH1=-2mA    | VDD-0.5 |     | V    |
|                      | VOH2   | P121~P124  | 4.0V≤VDD≤5.5V, IOH2=-2.5mA  | VDD-1.5 |     | V    |
|                      |        |  | 4.0V≤VDD≤5.5V, IOH2=-1.5mA  | VDD-0.7 |     | V    |
|                      |        |  | 2.4V≤VDD≤5.5V, IOH2=-0.5mA  | VDD-0.6 |     | V    |
|                      |        |  | 1.8V≤VDD≤5.5V, IOH2=-0.4mA  | VDD-0.5 |     | V    |
| Output voltage, low  | VOL1   | P00~P01, P10~P17, P20~P27, P30~P31, P40~P41, P50~P51, P60~P63, P70~P75, P120, P130, P136, P137, P140, P146, P147 | 4.0V≤VDD≤5.5V, IOL1=35.0mA  |         | 1.2 | V    |
|                      |        |  | 4.0V≤VDD≤5.5V, IOL1=20.0mA  |         | 0.7 | V    |
|                      |        |  | 2.4V≤VDD≤5.5V, IOL1=9.0mA   |         | 0.4 | V    |
|                      |        |  | 1.8V≤VDD≤5.5V, IOL1=6.0mA   |         | 0.4 | V    |
|                      | VOL2   | P121~P124  | 4.0V≤VDD≤5.5V, IOL2=10.0mA  |         | 1.2 | V    |
|                      |        |  | 4.0V≤VDD≤5.5V, IOL2=6.0mA   |         | 0.7 | V    |
|                      |        |  | 2.4V≤VDD≤5.5V, IOL2=2.5mA   |         | 0.4 | V    |
|                      |        |  | 1.8V≤VDD≤5.5V, IOL2=1.5mA   |         | 0.4 | V    |

Remark: Unless specified otherwise, the characteristics of alternate-function pins are the same as those of the port pins.

(TA=-40~+105°C, 1.8V≤VDD≤5.5V, VSS= 0V)

| Items                           | Symbol | Conditions   | MIN   | TYP | MAX | Unit |
|---------------------------------|--------|--|---|-----|-----|------|
| Input leakage current, high     | ILIH1  | P00~P01、P10~P17、P20~P27、P30~P31、P40~P41、P50~P51、P60~P63、P70~P75、P120、P130、P136、P137、P140、P146、P147 |   |     | 1   | μA   |
|                                 | ILIH2  | RESETB   |   |     | 1   | μA   |
|                                 | ILIH3  | P121~P124 (X1、X2、EXCLK、XT1、XT2、EXCLKS)   | VI=VDD, In input port or external clock input |     |     | 1    |
| VI=VDD, In resonator connection |        |  |   |     | 10  | μA   |
| Input leakage current, low      | ILIL1  | P00~P01、P10~P17、P20~P27、P30~P31、P40~P41、P50~P51、P60~P63、P70~P75、P120、P130、P136、P137、P140、P146、P147 |   |     | -1  | μA   |
|                                 | ILIL2  | RESETB   |   |     | -1  | μA   |
|                                 | ILIL3  | P121~P124 (X1、X2、EXCLK、XT1、XT2、EXCLKS)   | VI=VSS, In input port or external clock input |     |     | -1   |
| VI=VSS, In resonator connection |        |  |   |     | -10 | μA   |
| On-chip pull-up resistance      | RU     | P00~P01、P10~P17、P20~P27、P30~P31、P40~P41、P50~P51、P62~P63、P70~P75、P120、P130、P136、P137、P140、P146、P147 | 10  | 30  | 100 | kΩ   |
| On-chip pull-down resistance    | RD     | P00~P01、P10~P17、P20~P27、P30~P31、P50~P51、P62~P63、P70~P75、P120、P130、P136、P137、P140、P146、P147         | 10  | 30  | 100 | kΩ   |

Remark: Unless specified otherwise, the characteristics of alternate-function pins are the same as those of the port pins.

## 6.5.2 Supply Current Characteristics

( $T_A = -40 \sim +105^\circ\text{C}$ ,  $1.8\text{V} \leq V_{DD} \leq 5.5\text{V}$ ,  $V_{SS} = 0\text{V}$ )

| Parameter  | Symbol                        | Conditions                          |   | MIN.   | TYP.        | MAX. | Unit |      |    |
|--|-------------------------------|-------------------------------------|---|--|-------------|------|------|------|----|
| Supply current<br>Note 1   | $I_{DD1}$                     | Operating mode                      | High-speed on-chip oscillator   | $f_{HOCO}=64\text{MHz}$ , $f_{IH}=64\text{MHz}$ <sup>note3</sup> |             | 2.4  | 6.9  | mA   |    |
|  |                               |                                     |   | $f_{HOCO}=32\text{MHz}$ , $f_{IH}=32\text{MHz}$ <sup>note3</sup> |             | 1.6  | 4.6  |      |    |
|  |                               |                                     | high-speed main clock   | $f_{MX}=20\text{MHz}$ <sup>note2</sup>                           | Square wave |      | 1.0  | 3.1  | mA |
|  |                               |                                     |   |  | Resonator   |      | 1.0  | 3.1  |    |
|  |                               |                                     | high-speed SUB clock  | $f_{SUB}=32.768\text{KHz}$ <sup>note4</sup>                      | Square wave |      | 70   | 85   | uA |
|  |                               |                                     |   |  | Resonator   |      | 70   | 85   |    |
|  | Low-speed on-chip oscillator  | $f_{IL}=15\text{KHz}$ Note8         |   |  | 70          | 85   | uA   |      |    |
|  | $I_{DD2}$                     | Sleep mode                          | High-speed on-chip oscillator   | $f_{HOCO}=64\text{MHz}$ , $f_{IH}=64\text{MHz}$ <sup>note3</sup> |             | 1.8  | 4.0  | mA   |    |
|  |                               |                                     |   | $f_{HOCO}=32\text{MHz}$ , $f_{IH}=32\text{MHz}$ <sup>note3</sup> |             | 1.2  | 2.6  |      |    |
|  |                               |                                     | high-speed main clock   | $f_{MX}=20\text{MHz}$ <sup>note2</sup>                           | Square wave |      | 0.7  | 1.8  | mA |
|  |                               |                                     |   |  | Resonator   |      | 0.7  | 1.8  |    |
|  |                               |                                     | high-speed SUB clock  | $f_{SUB}=32.768\text{KHz}$ <sup>note5</sup>                      | Square wave |      | 0.7  | 12.5 | uA |
|  |                               |                                     |   |  | Resonator   |      | 0.7  | 12.5 |    |
|  | Low-speed on-chip oscillator  | $f_{IL}=15\text{KHz}$ Note8         |   |  | 0.9         | 13   |      |      |    |
|  | $I_{DD3}$<br><sup>note6</sup> | Deep Sleep mode<br><sup>note7</sup> | $T_A = -40^\circ\text{C} \sim +25^\circ\text{C}$ $V_{DD} = 3.0\text{V}$ |  |             | 0.45 | 1.0  | uA   |    |
| $T_A = -40^\circ\text{C} \sim +85^\circ\text{C}$ $V_{DD} = 3.0\text{V}$  |                               |                                     |   | 0.45   | 7.5         |      |      |      |    |
| $T_A = -40^\circ\text{C} \sim +105^\circ\text{C}$ $V_{DD} = 3.0\text{V}$ |                               |                                     |   | 0.45   | 12.5        |      |      |      |    |

Note:

- Total current flowing into VDD, including the input leakage current flowing when the level of the input pin is fixed to VDD or VSS. The values of the TYP. column include the current of the CPU executing the multiplication instruction (IDD1), not including the peripheral operation current. The values below the MAX. column include the current of the CPU executing the multiplication instruction (IDD1) and the peripheral operation current. However, not including the current flowing into the A/D converter, LVD circuit, I/O port, and on-chip pull-up/pull-down resistors and the current flowing during data flash rewrite.
- When high-speed on-chip oscillator and subsystem clock are stopped.
- When high-speed system clock and subsystem clock are stopped.
- When high-speed on-chip oscillator and high-speed system clock are stopped.
- When high-speed on-chip oscillator and high-speed system clock are stopped. The current flowing into the RTC is included.
- However, not including the current flowing into the 12-bit interval timer and watchdog timer.
- Not including the current flowing into the RTC, 12-bit interval timer, and watchdog timer.
- Regarding the value for current to operate the subsystem clock in DeepSleep mode, refer to that in Sleep mode.

9. When high-speed on-chip oscillator, high-speed system clock and subsystem clock are stopped.

Remark:

1. fHOCO: High-speed on-chip oscillator clock frequency. fIH: High-speed on-chip oscillator system clock frequency.
2. fSUB: Subsystem clock frequency (XT1/XT2 clock oscillation frequency).
3. fMX: High-speed system clock frequency (X1 clock oscillation frequency or external main system clock frequency).
4. fIL: Low-speed on-chip oscillator system clock frequency.
5. Temperature condition of the TYP. value is  $T_A = 25^{\circ}\text{C}$ .

( $T_A = -40 \sim +105^{\circ}\text{C}$ ,  $1.8\text{V} \leq V_{DD} \leq 5.5\text{V}$ ,  $V_{SS} = 0\text{V}$ )

| Parameter                                      | Symbol                    | Conditions         | MIN.  | TYP. | MAX. | Unit |    |
|--|---------------------------|--------------------|---|------|------|------|----|
| Low-speed on-chip oscillator operating current | IFIL <sup>note1</sup>     |                    |   | 0.2  |      | uA   |    |
| RTC operating current                          | IRTC <sup>note1,2,3</sup> |                    |   | 0.04 |      | uA   |    |
| 15-bit interval timer operating current        | IIT <sup>note1,2,4</sup>  |                    |   | 0.02 |      | uA   |    |
| Watchdog timer operating current               | IWDT <sup>note1,2,5</sup> | fIL=15KHz          |   | 0.22 |      | uA   |    |
| AD operating current                           | IADC <sup>note1,6</sup>   | ADC HS mode@64MHz  |   | 2.2  |      | mA   |    |
|  |                           | ADC HS mode @4MHz  |   | 1.3  |      | mA   |    |
|  |                           | ADC LC mode @24MHz |   | 1.1  |      | mA   |    |
|  |                           | ADC LC mode @4MHz  |   | 0.8  |      | mA   |    |
| PGA operating current                          |                           | Per PGA channel    |   | 480  | 700  | uA   |    |
| CMP operating current                          | ICMP <sup>note1,9</sup>   | Per CMP channel    | When the internal reference voltage is not in use |      | 60   | 100  | uA |
|  |                           |                    | When the internal reference voltage is in use     |      | 80   | 140  | uA |
| LVD operating current                          | ILVD <sup>note1,7</sup>   |                    |   | 0.08 |      | uA   |    |

Note:

1. Current flowing to VDD.
2. When high speed on-chip oscillator and high-speed system clock are stopped.
3. Current flowing only to the real-time clock (RTC) (excluding the operating current of the low-speed on-chip oscillator and the XT1 oscillator). The supply current of the microcontrollers is the sum of the values of either IDD1 or IDD2, and IRTC, when the real-time clock operates in operation mode or Sleep mode. When the low-speed on-chip oscillator is selected, IFIL should be added. IDD2 subsystem clock operation includes the operational current of the real-time clock.
4. Current flowing only to the 15-bit interval timer (excluding the operating current of the low-speed on-chip oscillator and the XT1 oscillator). The supply current of the microcontrollers is the sum of the values of either IDD1 or IDD2, and IIT, when the 15-bit interval timer operates in operation mode or Sleep mode. When the low-speed on-chip oscillator is selected, IFIL should be added.

5. Current flowing only to the watchdog timer (including the operating current of the low-speed on-chip oscillator).
6. Current flowing only to the A/D converter. The supply current of the microcontrollers is the sum of IDD1 or IDD2 and IADC when the A/D converter operates in an operation mode or the Sleep mode.
7. Current flowing only to the LVD circuit. The supply current of the microcontrollers is the sum of IDD1, IDD2 or IDD3 and ILVD when the LVD circuit is in operation.
8. Current flowing only to the D/A converter. The supply current of the microcontrollers is the sum of IDD1 or IDD2 and IDAC when the D/A converter operates in an operation mode or the Sleep mode.
9. Current flowing only to the comparator circuit. The supply current of the microcontrollers is the sum of IDD1, IDD2, or IDD3 and ICMP when the comparator circuit is in operation.

Remark:

1. f<sub>IL</sub>: Low-speed on-chip oscillator clock frequency
2. temperature condition of the TYP. value is TA = 25°C.



## 6.6 AC Characteristics

( $T_A = -40 \sim +105^\circ\text{C}$ ,  $1.8\text{V} \leq \text{VDD} \leq 5.5\text{V}$ ,  $\text{VSS} = 0\text{V}$ )

| Items   | Symbol          | Conditions                                     |  | MIN                  | TYP  | MAX  | Unit |
|---|-----------------|--|--|----------------------|------|------|------|
| Instruction cycle<br>(minimum<br>instruction<br>execution time)         | TCY             | Main system clock<br>(fMAIN) operation         | $1.8\text{V} \leq \text{VDD} \leq 5.5\text{V}$ | 0.015625             |      | 1    | us   |
|   |                 | Subsystem clock<br>(fSUB) operation            | $1.8\text{V} \leq \text{VDD} \leq 5.5\text{V}$ | 28.5                 | 30.5 | 31.3 | us   |
| External system<br>clock frequency                                      | fEX             | $1.8\text{V} \leq \text{VDD} \leq 5.5\text{V}$ |  | 1.0                  |      | 20.0 | MHz  |
|   | fEXS            | $1.8\text{V} \leq \text{VDD} \leq 5.5\text{V}$ |  | 32.0                 |      | 35.0 | KHz  |
| External system<br>clock input high-<br>level width,<br>low-level width | tEXH, tEXL      | $1.8\text{V} \leq \text{VDD} \leq 5.5\text{V}$ |  | 24                   |      |      | ns   |
|   | tEXHS,<br>tEXLS | $1.8\text{V} \leq \text{VDD} \leq 5.5\text{V}$ |  | 13.7                 |      |      | us   |
| Ti00 ~ Ti03, input<br>high-level width,<br>low-level width              | tTIH, tTIL      | $1.8\text{V} \leq \text{VDD} \leq 5.5\text{V}$ |  | $1/\text{fMCK} + 10$ |      |      | ns   |
| TO00 ~ TO03,<br>TO10 ~ T103,<br>output frequency                        | fTO             | $4.0\text{V} \leq \text{VDD} \leq 5.5\text{V}$ |  |                      |      | 16   | MHz  |
|   |                 | $2.4\text{V} \leq \text{VDD} < 4.0\text{V}$    |  |                      |      | 8    | MHz  |
|   |                 | $1.8\text{V} \leq \text{VDD} < 2.4\text{V}$    |  |                      |      | 4    | MHz  |
| CLKBUZ0,<br>CLKBUZ1 output<br>frequency                                 | fPCL            | $4.0\text{V} \leq \text{VDD} \leq 5.5\text{V}$ |  |                      |      | 16   | MHz  |
|   |                 | $2.4\text{V} \leq \text{VDD} < 4.0\text{V}$    |  |                      |      | 8    | MHz  |
|   |                 | $1.8\text{V} \leq \text{VDD} < 2.4\text{V}$    |  |                      |      | 4    | MHz  |
| Interrupt input high-<br>level width, low-<br>level width               | tINTH,<br>tINTL | INTP0 ~ INTP11                                 | $1.8\text{V} \leq \text{VDD} \leq 5.5\text{V}$ | 1                    |      |      | us   |
| Key interrupt input<br>low-level width                                  | tKR             | KR0 ~ KR5                                      | $1.8\text{V} \leq \text{VDD} \leq 5.5\text{V}$ | 250                  |      |      | ns   |
| RESETB low-level<br>width   | tRSL            |  |  | 10                   |      |      | us   |

Remark: fMCK: timer4 operation clock frequency

## 6.7 Peripheral Functions Characteristics

### 6.7.1 Serial Communication Interface

#### 1) UART mode

· ( $T_A = -40 \sim +85^\circ\text{C}$ ,  $1.8\text{V} \leq \text{VDD} \leq 5.5\text{V}$ ,  $\text{VSS} = 0\text{V}$ )

| Parameter     | Conditions                                     |  | Spec |                    | Unit |
|---------------|--|--|------|--------------------|------|
|               |  |  | MIN  | MAX                |      |
| Transfer rate | $1.8\text{V} \leq \text{VDD} \leq 5.5\text{V}$ | Theoretical value of the maximum transfer rate $f_{\text{MCK}} = f_{\text{CLK}}$ |      | $f_{\text{MCK}}/6$ | bps  |
|               |  |  |      | 10.6               | Mbps |

· ( $T_A = +85 \sim +105^\circ\text{C}$ ,  $1.8\text{V} \leq \text{VDD} \leq 5.5\text{V}$ ,  $\text{VSS} = 0\text{V}$ )

| Parameter     | Conditions                                     |  |     |                     | Unit |
|---------------|--|--|-----|---------------------|------|
|               |  |  | MIN | MAX                 |      |
| Transfer rate | $1.8\text{V} \leq \text{VDD} \leq 5.5\text{V}$ | Theoretical value of the maximum transfer rate $f_{\text{MCK}} = f_{\text{CLK}}$ |     | $f_{\text{MCK}}/12$ | bps  |
|               |  |  |     | 5.3                 | Mbps |

#### 2) 3-wire serial I/O(SSPI) (master mode, internal clock output)

( $T_A = -40 \sim +105^\circ\text{C}$ ,  $1.8\text{V} \leq \text{VDD} \leq 5.5\text{V}$ ,  $\text{VSS} = 0\text{V}$ )

| Parameter                   | Symbol        | Conditions                                     |  | $-40 \sim +85^\circ\text{C}$ |            | $+85 \sim +105^\circ\text{C}$ |     | Unit |
|-----------------------------|---------------|--|--|------------------------------|------------|-------------------------------|-----|------|
|                             |               |  |  | MIN                          | MAX        | MIN                           | MAX |      |
| SCLKp cycle time            | tKCY1         | $t_{\text{KCY1}} \geq 2/f_{\text{CLK}}$        | $4.0\text{V} \leq \text{VDD} \leq 5.5\text{V}$ | 31.25                        |            | 62.5                          |     | ns   |
|                             |               |  | $2.7\text{V} \leq \text{VDD} \leq 5.5\text{V}$ | 41.67                        |            | 83.3                          |     |      |
|                             |               |  | $2.4\text{V} \leq \text{VDD} \leq 5.5\text{V}$ | 65                           |            | 125                           |     | ns   |
|                             |               |  | $1.8\text{V} \leq \text{VDD} \leq 5.5\text{V}$ | 125                          |            | 250                           |     | ns   |
| SCLKp high-/low-level width | tKH1,<br>tKL1 | $4.0\text{V} \leq \text{VDD} \leq 5.5\text{V}$ | tKCY1/2-4                                      |                              | tKCY1/2-7  |                               | ns  |      |
|                             |               | $2.7\text{V} \leq \text{VDD} \leq 5.5\text{V}$ | tKCY1/2-5                                      |                              | tKCY1/2-10 |                               | ns  |      |
|                             |               | $2.4\text{V} \leq \text{VDD} \leq 5.5\text{V}$ | tKCY1/2-10                                     |                              | tKCY1/2-20 |                               | ns  |      |
|                             |               | $1.8\text{V} \leq \text{VDD} \leq 5.5\text{V}$ | tKCY1/2-19                                     |                              | tKCY1/2-38 |                               | ns  |      |
| SDIp setup time (to SCLKp↑) | tSIK1         | $4.0\text{V} \leq \text{VDD} \leq 5.5\text{V}$ | 12   |                              | 23         |                               | ns  |      |
|                             |               | $2.7\text{V} \leq \text{VDD} \leq 5.5\text{V}$ | 17   |                              | 33         |                               | ns  |      |
|                             |               | $2.4\text{V} \leq \text{VDD} \leq 5.5\text{V}$ | 20   |                              | 38         |                               | ns  |      |
|                             |               | $1.8\text{V} \leq \text{VDD} \leq 5.5\text{V}$ | 28   |                              | 55         |                               | ns  |      |
| SDIp hold time (from CLKp↑) | tKSI1         | $1.8\text{V} \leq \text{VDD} \leq 5.5\text{V}$ | 5  |                              | 10         |                               | ns  |      |

|                               |       |  |  |   |  |    |    |
|-------------------------------|-------|--|--|---|--|----|----|
| SCLKp↓→S<br>DOp Delay<br>time | tKSO1 | 1.8V ≤ VDD ≤ 5.5V<br>C = 20pF <sup>Note1</sup> |  | 5 |  | 10 | ns |
|-------------------------------|-------|--|--|---|--|----|----|

Note 1. C is the load capacitance of the SCLKp and SDOp output lines.

Caution: Select the normal input buffer for the SDIp pin and the normal output mode for the SDOp pin and SCLKp pin by using port input mode register g (PIMg) and port output mode register g (POMg).

### 3) 3-wire serial I/O(SSPI)(slave mode, external clock input)

(TA=-40~+105°C, 1.8V ≤ VDD ≤ 5.5V, Vss=0V)

| Parameter                             | Symbol        | Conditions                                   | -40 ~ +85°C  |                | +85 ~ +105°C      |            | Unit                |    |
|---------------------------------------|---------------|--|--------------|----------------|-------------------|------------|---------------------|----|
|                                       |               |  | MIN          | MAX            | MIN               | MAX        |                     |    |
| SCLKp<br>cycle time                   | tKCY2         | 4.0V ≤ VDD ≤ 5.5V                            | 20MHz < fMCK | 8/fMCK         |                   | 16/fMCK    | ns                  |    |
|                                       |               | 5.5V   | fMCK ≤ 20MHz | 6/fMCK         |                   | 12/fMCK    | ns                  |    |
|                                       |               | 2.7V ≤ VDD ≤ 5.5V                            | 16MHz < fMCK | 8/fMCK         |                   | 16/fMCK    | ns                  |    |
|                                       |               | 5.5V   | fMCK ≤ 16MHz | 6/fMCK         |                   | 12/fMCK    | ns                  |    |
|                                       |               | 2.4V ≤ VDD ≤ 5.5V                            |              |                | 6/fMCK<br>and 500 |            | 12/fMCK and<br>1000 | ns |
|                                       |               | 1.8V ≤ VDD ≤ 5.5V                            |              |                | 6/fMCK<br>and 750 |            | 12/fMCK and<br>1500 | ns |
| SCLKp<br>high-/low-<br>level width    | tKH2,<br>tKL2 | 4.0V ≤ VDD ≤ 5.5V                            |              | tKCY1/2-7      |                   | tKCY1/2-14 | ns                  |    |
|                                       |               | 2.7V ≤ VDD ≤ 5.5V                            |              | tKCY1/2-8      |                   | tKCY1/2-16 | ns                  |    |
|                                       |               | 1.8V ≤ VDD ≤ 5.5V                            |              | tKCY1/2-<br>18 |                   | tKCY1/2-36 | ns                  |    |
| SDIp setup<br>time<br>(to SCLKp↑)     | tSIK2         | 2.7V ≤ VDD ≤ 5.5V                            |              | 1/fMCK+20      |                   | 1/fMCK+40  | ns                  |    |
|                                       |               | 1.8V ≤ VDD ≤ 5.5V                            |              | 1/fMCK+30      |                   | 1/fMCK+60  | ns                  |    |
| SDIp hold<br>time<br>(from<br>SCLKp↑) | tKSI2         | 1.8V ≤ VDD ≤ 5.5V                            |              | 1/fMCK+31      |                   | 1/fMCK+62  | ns                  |    |
| SCLKp↓→S<br>DOp<br>Delay time         | tKSO2         | 2.7V ≤ VDD ≤ 5.5V<br>C=30pF <sup>note1</sup> |              |                | 2/fMCK<br>+44     |            | 2/fMCK<br>+66       | ns |
|                                       |               | 2.4V ≤ VDD ≤ 5.5V<br>C=30pF <sup>note1</sup> |              |                | 2/fMCK<br>+75     |            | 2/fMCK<br>+113      | ns |
|                                       |               | 1.8V ≤ VDD ≤ 5.5V<br>C=30pF <sup>note1</sup> |              |                | 2/fMCK<br>+100    |            | 2/fMCK<br>+150      | ns |

Note 1. C is the load capacitance of the SCLKp and SDOp output lines.

Caution: Select the normal input buffer for the SDIp pin and the normal output mode for the SDOp pin and SCLKp pin by using port input mode register g (PIMg) and port output mode register g (POMg).

## 4) 4-wire serial I/O(SPI) (slave mode, external clock input)

(TA=-40~+105°C, 1.8V≤VDD≤5.5V, Vss=0V)

| Parameter        | Symbol | Conditions | -40 ~ +85°C       |                | +85 ~ +105°C |            | Unit |
|------------------|--------|------------|-------------------|----------------|--------------|------------|------|
|                  |        |            | MIN               | MAX            | MIN          | MAX        |      |
| SSI00 setup time | tSSIK  | DAPmn=0    | 2.7V ≤ VDD ≤ 5.5V | 120            |              | 240        | ns   |
|                  |        |            | 1.8V ≤ VDD ≤ 5.5V | 200            |              | 400        | ns   |
|                  |        | DAPmn=1    | 2.7V ≤ VDD ≤ 5.5V | 1/fMCK+12<br>0 |              | 1/fMCK+240 | ns   |
|                  |        |            | 1.8V ≤ VDD ≤ 5.5V | 1/fMCK+20<br>0 |              | 1/fMCK+400 | ns   |
| SSI00 hold time  | tKSSI  | DAPmn=0    | 2.7V ≤ VDD ≤ 5.5V | 1/fMCK+12<br>0 |              | 1/fMCK+240 | ns   |
|                  |        |            | 1.8V ≤ VDD ≤ 5.5V | 1/fMCK+20<br>0 |              | 1/fMCK+400 | ns   |
|                  |        | DAPmn=1    | 2.7V ≤ VDD ≤ 5.5V | 120            |              | 240        | ns   |
|                  |        |            | 1.8V ≤ VDD ≤ 5.5V | 200            |              | 400        | ns   |

Caution: Select the normal input buffer for the SDIp pin and the normal output mode for the SDOp pin and SCLKp pin by using port input mode register g (PIMg) and port output mode register g (POMg).

5) simplified I<sup>2</sup>C mode

(TA=-40~+105°C, 2.0V≤EVDD=VDD≤5.5V, Vss=EVSS=0V)

| Parameter                        | Symbol  | Conditions                                       | -40 ~ +85°C                    |                       | +85 ~ +105°C                     |                      | Unit |
|----------------------------------|---------|--|--------------------------------|-----------------------|----------------------------------|----------------------|------|
|                                  |         |  | MIN                            | MAX                   | MIN                              | MAX                  |      |
| SCLr<br>clock frequency          | fSCL    | 2.7V ≤ EVDD ≤ 5.5V<br>Cb = 50 pF, Rb = 2.7<br>kΩ |                                | 1000 <sup>note1</sup> |                                  | 400 <sup>note1</sup> | KHz  |
|                                  |         | 1.8V ≤ EVDD ≤ 5.5V<br>Cb = 100 pF, Rb = 3 kΩ     |                                | 400 <sup>note1</sup>  |                                  | 100 <sup>note1</sup> | KHz  |
|                                  |         | 1.8V ≤ EVDD ≤ 2.7V<br>Cb = 100 pF, Rb = 5 kΩ     |                                | 300 <sup>note1</sup>  |                                  | 75 <sup>note1</sup>  | KHz  |
| Hold time<br>when SCLr = "L"     | tLOW    | 2.7V ≤ EVDD ≤ 5.5V<br>Cb = 50 pF, Rb = 2.7<br>kΩ | 475                            |                       | 1200                             |                      | ns   |
|                                  |         | 1.8V ≤ EVDD ≤ 5.5V<br>Cb = 100 pF, Rb = 3 kΩ     | 1150                           |                       | 4600                             |                      | ns   |
|                                  |         | 1.8V ≤ EVDD ≤ 2.7V<br>Cb = 100 pF, Rb = 5 kΩ     | 1550                           |                       | 6500                             |                      | ns   |
| Hold time<br>when SCLr =<br>"H"  | tHIGH   | 2.7V ≤ EVDD ≤ 5.5V<br>Cb = 50 pF, Rb = 2.7<br>kΩ | 475                            |                       | 1200                             |                      | ns   |
|                                  |         | 1.8V ≤ EVDD ≤ 5.5V<br>Cb = 100 pF, Rb = 3 kΩ     | 1150                           |                       | 4600                             |                      | ns   |
|                                  |         | 1.8V ≤ EVDD ≤ 2.7V<br>Cb = 100 pF, Rb = 5 kΩ     | 1550                           |                       | 6500                             |                      | ns   |
| Data setup time<br>(reception)   | tSU:DAT | 2.7V ≤ EVDD ≤ 5.5V<br>Cb = 50 pF, Rb = 2.7<br>kΩ | 1/fMCK+85<br><sup>note2</sup>  |                       | 1/fMCK+<br>220 <sup>note2</sup>  |                      | ns   |
|                                  |         | 1.8V ≤ EVDD ≤ 5.5V<br>Cb = 100 pF, Rb = 3 kΩ     | 1/fMCK+145<br><sup>note2</sup> |                       | 1/fMCK+<br>580 <sup>note2</sup>  |                      | ns   |
|                                  |         | 1.8V ≤ EVDD ≤ 2.7V<br>Cb = 100 pF, Rb = 5 kΩ     | 1/fMCK+230<br><sup>note2</sup> |                       | 1/fMCK+<br>1200 <sup>note2</sup> |                      | ns   |
| Data hold time<br>(transmission) | tHD:DAT | 2.7V ≤ EVDD ≤ 5.5V<br>Cb = 50 pF, Rb = 2.7<br>kΩ |                                | 305                   |                                  | 770                  | ns   |
|                                  |         | 1.8V ≤ EVDD ≤ 5.5V<br>Cb = 100 pF, Rb = 3 kΩ     |                                | 355                   |                                  | 1420                 | ns   |
|                                  |         | 1.8V ≤ EVDD ≤ 2.7V<br>Cb = 100 pF, Rb = 5 kΩ     |                                | 405                   |                                  | 2070                 | ns   |

Note:

1. The value must also be equal to or less than fMCK/4.
2. Set the fMCK value to keep the hold time of SCLr = "L" and SCLr = "H".

## 6.7.2 Serial Interface IICA

### 1) I<sup>2</sup>C standard mode

(TA=-40~+105°C, 1.8V≤VDD≤5.5V, VSS=0V)

| Parameter                                       | Symbol  | Conditions               | Spec |      | Unit |
|---|---------|--------------------------|------|------|------|
|   |         |                          | MIN  | MAX  |      |
| SCLA0 clock frequency                           | fSCL    | Standard mode: fCLK≥1MHz |      | 100  | KHz  |
| Setup time of restart condition                 | tSU:STA |                          | 4.7  |      | us   |
| Hold time <sup>Note 1</sup>                     | tHD:STA |                          | 4.0  |      | us   |
| Hold time when SCLA0 = "L"                      | tLOW    |                          | 4.7  |      | us   |
| Hold time when SCLA0 = "H"                      | tHIGH   |                          | 4.0  |      | us   |
| Data setup time (reception)                     | tSU:DAT |                          | 250  |      | ns   |
| Data hold time (transmission) <sup>Note 2</sup> | tHD:DAT |                          | 0    | 3.45 | us   |
| Setup time of stop condition                    | tSU:STO |                          | 4.0  |      | us   |
| Bus-free time                                   | tBUF    |                          | 4.7  |      | us   |

Note:

1. The first clock pulse is generated after this period when the start/restart condition is detected.
2. The maximum value (MAX.) of tHD: DAT is during normal transfer and a wait state is inserted in the ACK (acknowledge) timing.

Remark:

The maximum value of C<sub>b</sub> (communication line capacitance) and the value of R<sub>b</sub> (communication line pull-up resistor) at that time in each mode are as follows.

Standard mode: C<sub>b</sub>=400pF, R<sub>b</sub>=2.7kΩ

2) I<sup>2</sup>C fast mode

(TA=-40~+105°C, 1.8V≤VDD≤5.5V, VSS=0V)

| Parameter                                       | Symbol  | Conditions             | Spec |     | Unit |
|---|---------|------------------------|------|-----|------|
|   |         |                        | MIN  | MAX |      |
| SCLA0 clock frequency                           | fSCL    | Fast mode: fCLK≥3.5MHz |      | 400 | KHz  |
| Setup time of restart condition                 | tSU:STA |                        | 0.6  |     | us   |
| Hold time <sup>Note 1</sup>                     | tHD:STA |                        | 0.6  |     | us   |
| Hold time when SCLA0 = "L"                      | tLOW    |                        | 1.3  |     | us   |
| Hold time when SCLA0 = "H"                      | tHIGH   |                        | 0.6  |     | us   |
| Data setup time (reception)                     | tSU:DAT |                        | 100  |     | ns   |
| Data hold time (transmission) <sup>Note 2</sup> | tHD:DAT |                        | 0    | 0.9 | us   |
| Setup time of stop condition                    | tSU:STO |                        | 0.6  |     | us   |
| Bus-free time                                   | tBUF    |                        | 1.3  |     | us   |

Note:

1. The first clock pulse is generated after this period when the start/restart condition is detected.
2. The maximum value (MAX.) of tHD: DAT is during normal transfer and a wait state is inserted in the ACK (acknowledge) timing.

Remark:

The maximum value of C<sub>b</sub> (communication line capacitance) and the value of R<sub>b</sub> (communication line pull-up resistor) at that time in each mode are as follows.

 Fast mode:C<sub>b</sub>=320pF, R<sub>b</sub>=1.1kΩ

3) I<sup>2</sup>C fast mode plus

(TA=-40~+105°C, 1.8V≤VDD≤5.5V, VSS=0V)

| Parameter  | Symbol  | Conditions                 | Spec |      | Unit |
|--|---------|----------------------------|------|------|------|
|  |         |                            | MIN  | MAX  |      |
| SCLA0 clock frequency                              | fSCL    | Fast mode plus: fCLK≥10MHz |      | 1000 | KHz  |
| Setup time of restart condition                    | tSU:STA |                            | 0.26 |      | us   |
| Hold time <sup>Note 1</sup>                        | tHD:STA |                            | 0.26 |      | us   |
| Hold time when SCLA0 = "L"                         | tLOW    |                            | 0.5  |      | us   |
| Hold time when SCLA0 = "H"                         | tHIGH   |                            | 0.26 |      | us   |
| Data setup time (reception)                        | tSU:DAT |                            | 50   |      | ns   |
| Data hold time (transmission)<br><sup>Note 2</sup> | tHD:DAT |                            | 0    | 0.45 | us   |
| Setup time of stop condition                       | tSU:STO |                            | 0.26 |      | us   |
| Bus-free time                                      | tBUF    |                            | 0.5  |      | us   |

## Note:

1. The first clock pulse is generated after this period when the start/restart condition is detected.
2. The maximum value (MAX.) of tHD: DAT is during normal transfer and a wait state is inserted in the ACK (acknowledge) timing.

## Remark:

The maximum value of C<sub>b</sub> (communication line capacitance) and the value of R<sub>b</sub> (communication line pull-up resistor) at that time in each mode are as follows.

Fast mode plus: C<sub>b</sub>=120pF, R<sub>b</sub>=1.1kΩ



## 6.8 Analog Characteristics

### 6.8.1 A/D Converter Characteristics

Classification of A/D converter characteristics

| Input channel   | Reference Voltage | Reference voltage(+)=AVREFP<br>Reference voltage(-)=AVREFM | Reference voltage(+)=VDD<br>Reference voltage(-)=VSS |
|---|-------------------|--|--|
| ANI0~ANI36  |                   | Refer to 6.8.1 (1)   | Refer to 6.8.1(2)                                    |
| Internal reference voltage<br>Temperature sensor output voltage |                   |  |  |

1) When reference voltage (+)=AVREFP/ANI0, reference voltage (-)=AVREFM/ANI1

( $T_A = -40 \sim +105^{\circ}\text{C}$ ,  $1.8\text{V} \leq \text{AVREFP} \leq \text{VDD} \leq 5.5\text{V}$ ,  $\text{VSS} = 0\text{V}$ , reference voltage(+)=AVREFP, reference voltage(-)=AVREFM=0V)

| Parameter                                      | Symbol            | Conditions   |   | MIN.                               | TYP.                 | MAX.            | Unit       |
|--|-------------------|--|---|------------------------------------|----------------------|-----------------|------------|
| Resolution                                     | RES               |  |   |                                    | 12                   |                 | bit        |
| Overall error <sup>Note 1</sup>                | ET                | 12-bit resolution  | $1.8\text{V} \leq \text{AVREFP} \leq 5.5\text{V}$ |                                    | 3                    |                 | LSB        |
| Zero-scale error <sup>Note 1</sup>             | EZS               | 12-bit resolution  | $1.8\text{V} \leq \text{AVREFP} \leq 5.5\text{V}$ |                                    | 0                    |                 | LSB        |
| Full-scale error <sup>Note 1</sup>             | EFS               | 12-bit resolution  | $1.8\text{V} \leq \text{AVREFP} \leq 5.5\text{V}$ |                                    | 0                    |                 | LSB        |
| Integral linearity error <sup>Note 1</sup>     | EL                | 12-bit resolution  | $1.8\text{V} \leq \text{AVREFP} \leq 5.5\text{V}$ | -1                                 |                      | 1               | LSB        |
| Differential linearity error <sup>Note 1</sup> | ED                | 12-bit resolution  | $1.8\text{V} \leq \text{AVREFP} \leq 5.5\text{V}$ | -1.5                               |                      | 1.5             | LSB        |
| Conversion time <sup>Note3</sup>               | $t_{\text{CONV}}$ | 12-bit resolution<br>Target pin: ANI2~ANI36  | $1.8\text{V} \leq \text{VDD} \leq 5.5\text{V}$    | 45                                 |                      |                 | 1/fadc     |
|  |                   | 12-bit resolution<br>Target pin: Internal reference voltage, and temperature sensor output voltage, PGA output voltage | $1.8\text{V} \leq \text{VDD} \leq 5.5\text{V}$    | 72                                 |                      |                 | 1/fadc     |
| External input resistance                      | $R_{\text{AIN}}$  | $R_{\text{AIN}} < (T_s / (\text{fad} \times \text{Cadc} \times \ln(2^{12+2})) - R_{\text{ADC}})$                       |   |                                    | 7.5 <sup>Note4</sup> |                 | k $\Omega$ |
| Sampling switch resistance                     | $R_{\text{ADC}}$  |  |   |                                    |                      | 1.5             | k $\Omega$ |
| Sample and hold capacitance                    | $C_{\text{ADC}}$  |  |   |                                    | 2                    |                 | pF         |
| Analog input voltage                           | $V_{\text{AIN}}$  | ANI2~ANI36   |   | 0                                  |                      | $\text{AVREFP}$ | V          |
|  |                   | Internal reference voltage ( $1.8\text{V} \leq \text{VDD} \leq 5.5\text{V}$ )  |   | $V_{\text{BGR}}$ <sup>Note2</sup>  |                      |                 | V          |
|  |                   | Temperature sensor output voltage ( $1.8\text{V} \leq \text{VDD} \leq 5.5\text{V}$ )                                   |   | $V_{\text{TMPS}}$ <sup>Note2</sup> |                      |                 | V          |

**Note:**

- 1) Excludes quantization error ( $\pm 1/2$  LSB).
- 2) Refer to “6.8.2 Temperature sensor characteristics/internal reference voltage characteristic”.
- 3) Tmclk is the operating clock cycle of AD, and the maximum operating frequency is 48MHz.
- 4) Guaranteed by design, mass production without testing. The typical value is the default sampling period  $T_S = 13.5$ , and the conversion speed is the calculated value under the condition of fad = 64 MHz.

- 2) When reference voltage (+) =VDD, reference voltage (-) =VSS  
 $(T_A = -40 \sim +105^\circ\text{C}, 1.8\text{V} \leq V_{DD} \leq 5.5\text{V}, V_{SS} = V_{VSS} = 0\text{V}, \text{reference voltage (+)} = V_{DD}, \text{reference voltage (-)} = V_{SS})$

| Parameter                                      | Symbol           | Conditions   |  | MIN.                                | TYP.                  | MAX.            | Unit   |
|--|------------------|--|--|-------------------------------------|-----------------------|-----------------|--------|
| Resolution                                     | RES              |  |  |                                     | 12                    |                 | bit    |
| Overall error <sup>Note 1</sup>                | ET               | 12-bit resolution  | $1.8\text{V} \leq V_{REFP} \leq 5.5\text{V}$ |                                     | 6                     |                 | LSB    |
| Zero-scale error <sup>Note 1</sup>             | EZS              | 12-bit resolution  | $1.8\text{V} \leq V_{REFP} \leq 5.5\text{V}$ |                                     | 0                     |                 | LSB    |
| Full-scale error <sup>Note 1</sup>             | EFS              | 12-bit resolution  | $1.8\text{V} \leq V_{REFP} \leq 5.5\text{V}$ |                                     | 0                     |                 | LSB    |
| Integral linearity error <sup>Note 1</sup>     | EL               | 12-bit resolution  | $1.8\text{V} \leq V_{REFP} \leq 5.5\text{V}$ | -2                                  |                       | 2               | LSB    |
| Differential linearity error <sup>Note 1</sup> | ED               | 12-bit resolution  | $1.8\text{V} \leq V_{REFP} \leq 5.5\text{V}$ | -3                                  |                       | 3               | LSB    |
| Conversion time <sup>Note 3</sup>              | tCONV            | 12-bit resolution<br>Target pin: ANI2~ANI36  | $1.8\text{V} \leq V_{DD} \leq 5.5\text{V}$   | 45                                  |                       |                 | 1/fadc |
|  |                  | 12-bit resolution<br>Target pin: Internal reference voltage, and temperature sensor output voltage, PGA output voltage | $1.8\text{V} \leq V_{DD} \leq 5.5\text{V}$   | 72                                  |                       |                 | 1/fadc |
| External input resistance                      | R <sub>AIN</sub> | $R_{AIN} < (T_s / (f_{ad} \times C_{adc} \times \ln(2^{12+2})) - R_{ADC})$   |  |                                     | 7.5 <sup>Note 4</sup> |                 | kΩ     |
| Sampling switch resistance                     | R <sub>ADC</sub> |  |  |                                     |                       | 1.5             | kΩ     |
| Sample and hold capacitance                    | C <sub>ADC</sub> |  |  |                                     | 2                     |                 | pF     |
| Analog input voltage                           | V <sub>AIN</sub> | ANI0~ANI36   |  | 0                                   |                       | V <sub>DD</sub> | V      |
|  |                  | Internal reference voltage<br>( $1.8\text{V} \leq V_{DD} \leq 5.5\text{V}$ )   |  | V <sub>BGR</sub> <sup>Note 2</sup>  |                       |                 | V      |
|  |                  | Temperature sensor output voltage<br>( $1.8\text{V} \leq V_{DD} \leq 5.5\text{V}$ )                                    |  | V <sub>TMPS</sub> <sup>Note 2</sup> |                       |                 | V      |

**Note:**

- 1) Excludes quantization error ( $\pm 1/2$  LSB).
- 2) Refer to “6.8.2 Temperature sensor characteristics/internal reference voltage characteristic”.
- 3) Tmclk is the operating clock cycle of AD, and the maximum operating frequency is 64MHz.
- 4) Guaranteed by design, mass production without testing. The typical value is the default sampling period  $T_S = 13.5$ , and the conversion speed is the calculated value under the condition of fad = 64 MHz.

## 6.8.2 Temperature Sensor Characteristics/Internal Reference

### Voltage Characteristic

( $T_A = -40 \sim +105^\circ\text{C}$ ,  $1.8\text{V} \leq \text{VDD} \leq 5.5\text{V}$ ,  $\text{VSS} = 0\text{V}$ )

| Parameter                         | Symbol  | Conditions                           | MIN                   | TYP  | MAX                   | Unit                 |
|-----------------------------------|---------|--------------------------------------|-----------------------|------|-----------------------|----------------------|
| Temperature sensor output voltage | VTMPS25 | ADS = 80H, $T_A = +25^\circ\text{C}$ |                       | 1.09 |                       | V                    |
| Internal reference voltage        | VBGR    | $T_A = -40 \sim -10^\circ\text{C}$   | 1.25 <sup>Note1</sup> | 1.45 | 1.65 <sup>Note1</sup> | V                    |
|                                   |         | $T_A = 10 \sim 70^\circ\text{C}$     | 1.38 <sup>Note1</sup> | 1.45 | 1.50 <sup>Note1</sup> | V                    |
|                                   |         | $T_A = 70 \sim 105^\circ\text{C}$    | 1.30 <sup>Note1</sup> | 1.45 | 1.60 <sup>Note1</sup> | V                    |
| Temperature coefficient           | FVTMPS  |                                      |                       | -3.5 |                       | mV/ $^\circ\text{C}$ |
| Operation stabilization wait time | tAMP    |                                      | 5                     |      |                       | us                   |

Note:

1. The low temperature specification value is guaranteed by the design, and the low temperature condition is not measured for mass production.

## 6.8.3 Comparator

( $T_A = -40 \sim +105^\circ\text{C}$ ,  $1.8\text{V} \leq \text{VDD} \leq 5.5\text{V}$ ,  $\text{VSS} = 0\text{V}$ )

| Parameter                                      | Symbol                   | Conditions  | MIN             | TYP      | MAX      | Unit |
|--|--------------------------|---|-----------------|----------|----------|------|
| Input offset voltage                           | $V_{\text{IOCOMP}}$      |   |                 | $\pm 10$ | $\pm 40$ | mV   |
| Input voltage range                            | Ivcmp                    |   | 0               |          | VDD      | V    |
| Internal reference voltage deviation           | $\Delta V_{\text{IREF}}$ | CmRVM register value : 7FH ~ 80H (m = 0, 1)                                 |                 |          | $\pm 2$  | LSB  |
|  |                          | Other than above  |                 |          | $\pm 1$  | LSB  |
| Response Time                                  | tCR, tCF                 | Input amplitude $\pm 100\text{mV}$  |                 | 70       | 150      | ns   |
| Operation stabilization Time <sup>Note 1</sup> | tCMP                     | CMPn=0->1   | VDD= 3.3 ~ 5.5V |          | 1        | us   |
|  |                          |   | VDD= 1.8 ~ 3.3V |          | 3        |      |
| Reference voltage stabilization wait time      | tVR                      | CVRE=0->1 <sup>Note2</sup>  |                 |          | 20       | us   |
| Operation current                              | $I_{\text{CMPDD}}$       | Separately, it is defined as the operation current of peripheral functions. |                 |          |          |      |

Note1: Time taken until the comparator satisfies the DC/AC characteristics after the comparator operation enable signal is switched (CMPnEN = 0 → 1).

Note2: Enable comparator output (CnOE bit = 1; n = 0 to 1) after enabling operation of the internal reference voltage generator

(by setting the CVREm bit to 1; m = 0 to 1) and waiting for the operation stabilization time to elapse.

## 6.8.4 PGA

( $T_A = -40 \sim +105^\circ\text{C}$ ,  $1.8\text{V} \leq \text{VDD} \leq 5.5\text{V}$ ,  $\text{VSS} = 0\text{V}$ )

| Parameter   | Symbol                    | Conditions  | MIN  | TYP     | MAX                                   | Unit |
|---|---------------------------|---|--|---------|---------------------------------------|------|
| Input offset voltage  | $V_{IO\text{PGA}}$        |   |  | $\pm 3$ | $\pm 10$                              | mV   |
| Input voltage range   | $V_{IP\text{PGA}}$        |   | 0  |         | $0.9 \times \text{VDD} / \text{Gain}$ | V    |
| Output voltage range  | $V_{IOH\text{PGA}}$       |   | $0.93 \times \text{VDD}$   |         |                                       | V    |
|   | $V_{IOL\text{PGA}}$       |   |  |         | $0.07 \times \text{VDD}$              | V    |
| Gain error  |                           | x4  |  |         | $\pm 1$                               | %    |
|   |                           | x8  |  |         | $\pm 1$                               | %    |
|   |                           | x10   |  |         | $\pm 1$                               | %    |
|   |                           | x12   |  |         | $\pm 2$                               | %    |
|   |                           | x14   |  |         | $\pm 2$                               | %    |
|   |                           | x16   |  |         | $\pm 2$                               | %    |
|   |                           | x32   |  |         | $\pm 3$                               | %    |
| Slew rate   | $\text{SR}_{\text{RPGA}}$ | Rising $V_{in} = 0.1\text{VDD}/\text{gain}$ to $0.9\text{VDD}/\text{gain}$ . 10 to 90% of output voltage amplitude  | $4.0\text{V} \leq \text{VDD} \leq 5.5\text{V}$<br>(Other than x32) | 3.5     |                                       | V/us |
|   |                           |   | $4.0\text{V} \leq \text{VDD} \leq 5.5\text{V}$<br>(x32)            | 3.0     |                                       |      |
|   |                           |   | $2.0\text{V} \leq \text{VDD} \leq 4.0\text{V}$                     | 0.5     |                                       |      |
|   | $\text{SR}_{\text{FPGA}}$ | Falling $V_{in} = 0.1\text{VDD}/\text{gain}$ to $0.9\text{VDD}/\text{gain}$ . 90 to 10% of output voltage amplitude | $4.0\text{V} \leq \text{VDD} \leq 5.5\text{V}$<br>(Other than x32) | 3.5     |                                       |      |
|   |                           |   | $4.0\text{V} \leq \text{VDD} \leq 5.5\text{V}$<br>(x32)            | 3.0     |                                       |      |
|   |                           |   | $2.0\text{V} \leq \text{VDD} \leq 4.0\text{V}$                     | 0.5     |                                       |      |
| Reference voltage stabilization wait time <small>Note 1</small> | $t_{\text{PGA}}$          | x4  |  |         | 5                                     | us   |
|   |                           | x8  |  |         | 5                                     | us   |
|   |                           | x10   |  |         | 5                                     | us   |
|   |                           | x12   |  |         | 10                                    | us   |
|   |                           | x14   |  |         | 10                                    | us   |
|   |                           | x16   |  |         | 10                                    | us   |
|   |                           | x32   |  |         | 10                                    | us   |
| Operation current   | $I_{\text{PGADD}}$        | Separately, it is defined as the operation current of peripheral functions.   |  |         |                                       |      |

Note1. Time required until a state is entered where the DC and AC specifications of the PGA are satisfied after the PGA operation has been enabled (PGAEN = 1).

## 6.8.5 POR Circuit Characteristics

( $T_A = -40 \sim +105^\circ\text{C}$ ,  $V_{SS} = 0\text{V}$ )

| Parameter                             | Symbol | Conditions                       | MIN  | TYP  | MAX  | Unit |
|---------------------------------------|--------|----------------------------------|------|------|------|------|
| Power on/down reset threshold         | VPOR   | Voltage threshold on VDD rising  |      | 1.50 | 1.75 | V    |
|                                       | VPDR   | Voltage threshold on VDD falling | 1.37 | 1.45 |      | V    |
| Minimum pulse width <sup>Note 1</sup> | TPW    |                                  | 300  |      |      | us   |

Note1. Minimum time required for a POR reset when VDD exceeds below VPDR. This is also the minimum time required for a POR reset from when VDD exceeds below 0.7 V to when VDD exceeds VPOR while STOP mode is entered or the main system clock is stopped through setting bit 0 (HIOSTOP) and bit 7 (MSTOP) in the clock operation status control register (CSC).

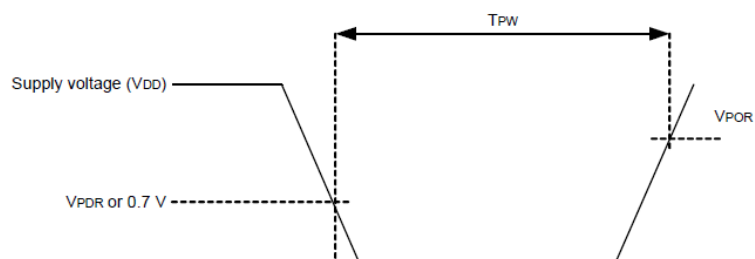

## 6.8.6 LVD Circuit Characteristics

### 1) Reset Mode and Interrupt Mode

( $T_A = -40 \sim +105^\circ\text{C}$ ,  $V_{PDR} \leq V_{DD} \leq 5.5\text{V}$ ,  $V_{SS} = 0\text{V}$ )

| Parameter                   | Symbol          | Conditions   | MIN  | TYP  | MAX  | Unit |
|-----------------------------|-----------------|--------------|------|------|------|------|
| Voltage detection threshold | VLVD0           | Rising edge  |      | 4.06 | 4.14 | V    |
|                             |                 | Falling edge | 3.78 | 3.98 |      | V    |
|                             | VLVD1           | Rising edge  |      | 3.75 |      | V    |
|                             |                 | Falling edge |      | 3.67 |      | V    |
|                             | VLVD2           | Rising edge  |      | 3.13 |      | V    |
|                             |                 | Falling edge |      | 3.06 |      | V    |
|                             | VLVD3           | Rising edge  |      | 3.02 |      | V    |
|                             |                 | Falling edge |      | 2.96 |      | V    |
|                             | VLVD4           | Rising edge  |      | 2.92 |      | V    |
|                             |                 | Falling edge |      | 2.86 |      | V    |
|                             | VLVD5           | Rising edge  |      | 2.81 |      | V    |
|                             |                 | Falling edge |      | 2.75 |      | V    |
|                             | VLVD6           | Rising edge  |      | 2.71 |      | V    |
|                             |                 | Falling edge |      | 2.65 |      | V    |
|                             | VLVD7           | Rising edge  |      | 2.61 |      | V    |
|                             |                 | Falling edge |      | 2.55 |      | V    |
|                             | VLVD8           | Rising edge  |      | 2.50 |      | V    |
|                             |                 | Falling edge |      | 2.45 |      | V    |
|                             | VLVD9           | Rising edge  |      | 2.09 |      | V    |
|                             |                 | Falling edge |      | 2.04 |      | V    |
|                             | VLVD10          | Rising edge  |      | 1.98 |      | V    |
|                             |                 | Falling edge |      | 1.94 |      | V    |
| VLVD11                      | Rising edge     |              | 1.88 | 1.91 | V    |      |
|                             | Falling edge    |              | 1.80 | 1.84 | V    |      |
| Minimum pulse width         | t <sub>LW</sub> |              | 300  |      |      | us   |
| Detection delay time        |                 |              |      |      | 300  | us   |

## 2) Interrupt &amp; Reset Mode

(TA=-40~+105°C, VPDR ≤VDD≤5.5V, VSS=0V)

| Parameter                   | Symbol            | Conditions   | MIN                          | TYP  | MAX  | Unit |   |
|-----------------------------|-------------------|--|------------------------------|------|------|------|---|
| Voltage detection threshold | VLVDA0            | VPOC2, VPOC1, VPOC0=0, 0, 0, falling reset voltage | 1.60                         | 1.63 |      | V    |   |
|                             | VLVDA1            | LVIS1, LVIS0=1, 0                                  | Rising release reset voltage |      | 1.77 | 1.81 | V |
|                             |                   |  | Falling interrupt voltage    | 1.70 | 1.73 |      | V |
|                             | VLVDA2            | LVIS1, LVIS0=0, 1                                  | Rising release reset voltage |      | 1.88 |      | V |
|                             |                   |  | Falling interrupt voltage    |      | 1.84 |      | V |
|                             | VLVDA3            | LVIS1, LVIS0=0, 0                                  | Rising release reset voltage |      | 2.92 |      | V |
|                             |                   |  | Falling interrupt voltage    |      | 2.86 |      | V |
|                             | VLVDB0            | VPOC2, VPOC1, VPOC0=0, 0, 1, falling reset voltage |                              | 1.84 |      | V    |   |
|                             | VLVDB1            | LVIS1, LVIS0=1, 0                                  | Rising release reset voltage |      | 1.98 |      | V |
|                             |                   |  | Falling interrupt voltage    |      | 1.94 |      | V |
|                             | VLVDB2            | LVIS1, LVIS0=0, 1                                  | Rising release reset voltage |      | 2.09 |      | V |
|                             |                   |  | Falling interrupt voltage    |      | 2.04 |      | V |
|                             | VLVDB3            | LVIS1, LVIS0=0, 0                                  | Rising release reset voltage |      | 3.13 |      | V |
|                             |                   |  | Falling interrupt voltage    |      | 3.06 |      | V |
|                             | VLVDC0            | VPOC2, VPOC1, VPOC0=0, 1, 0, falling reset voltage |                              | 2.45 |      | V    |   |
|                             | VLVDC1            | LVIS1, LVIS0=1, 0                                  | Rising release reset voltage |      | 2.61 |      | V |
|                             |                   |  | Falling interrupt voltage    |      | 2.55 |      | V |
|                             | VLVDC2            | LVIS1, LVIS0=0, 1                                  | Rising release reset voltage |      | 2.71 |      | V |
|                             |                   |  | Falling interrupt voltage    |      | 2.65 |      | V |
|                             | VLVDC3            | LVIS1, LVIS0=0, 0                                  | Rising release reset voltage |      | 3.75 |      | V |
|                             |                   |  | Falling interrupt voltage    |      | 3.67 |      | V |
|                             | VLVDD0            | VPOC2, VPOC1, VPOC0=0, 1, 1, falling reset voltage |                              | 2.75 |      | V    |   |
|                             | VLVDD1            | LVIS1, LVIS0=1, 0                                  | Rising release reset voltage |      | 2.92 |      | V |
|                             |                   |  | Falling interrupt voltage    |      | 2.86 |      | V |
| VLVDD2                      | LVIS1, LVIS0=0, 1 | Rising release reset voltage                       |                              | 3.02 |      | V    |   |
|                             |                   | Falling interrupt voltage                          |                              | 2.96 |      | V    |   |
| VLVDD3                      | LVIS1, LVIS0=0, 0 | Rising release reset voltage                       |                              | 4.06 | 4.14 | V    |   |
|                             |                   | Falling interrupt voltage                          | 3.90                         | 3.98 |      | V    |   |

## 6.8.7 Reset Time and Power Supply Voltage Rising Slope Characteristics

( $T_A = -40 \sim +105^\circ\text{C}$ ,  $V_{SS} = 0\text{V}$ )

| Parameter                         | Symbol             | Conditions | MIN | TYP | MAX | Unit |
|-----------------------------------|--------------------|------------|-----|-----|-----|------|
| Reset time                        | $T_{\text{RESET}}$ |            |     | 1   |     | Ms   |
| Power supply voltage rising slope | SVDD               |            |     |     | 54  | V/ms |



## 6.9 Memory Characteristics

### 6.9.1 Flash Memory

( $T_A = -40 \sim +105^\circ\text{C}$ ,  $1.8\text{V} \leq \text{VDD} \leq 5.5\text{V}$ ,  $\text{VSS} = 0\text{V}$ )

| Symbol           | Parameter           | Conditions                                 | MIN | MAX | Unit   |
|------------------|---------------------|--|-----|-----|--------|
| Tprog            | Word Program(32bit) | $T_A = -40 \sim +105^\circ\text{C}$        | 24  | 30  | us     |
| Terase           | Sector erase(512B)  | $T_A = -40 \sim +105^\circ\text{C}$        | 4   | 5   | ms     |
|                  | Chip erase          | $T_A = -40 \sim +105^\circ\text{C}$        | 20  | 40  | ms     |
| N <sub>END</sub> | Endurance           | $T_A = -40 \sim +105^\circ\text{C}$        | 100 |     | kcycle |
| t <sub>RET</sub> | Data retention      | 100 kcycle(2) at $T_A = 105^\circ\text{C}$ | 20  |     | Years  |

Note1: Data based on characterization results, not tested in production.

Note2: Cycling performed over the whole temperature range.

### 6.9.2 RAM Memory

( $T_A = -40 \sim +105^\circ\text{C}$ ,  $1.8\text{V} \leq \text{VDD} \leq 5.5\text{V}$ ,  $\text{VSS} = 0\text{V}$ )

| Symbol   | Parameter        | Conditions                          | MIN | MAX | Unit |
|----------|------------------|-------------------------------------|-----|-----|------|
| Vramhold | RAM Hold Voltage | $T_A = -40 \sim +105^\circ\text{C}$ | 0.8 |     | V    |

## 6.10 Electrical Sensitivity Characteristics

### 6.10.1 Electrostatic Discharge (ESD)

| Symbol    | Parameter   | Conditions                            | Class |
|-----------|---|---------------------------------------|-------|
| VESD(HBM) | Electrostatic discharge voltage<br>(human body model) | TA = +25°C, conforming to JESD22-A114 | 3A    |

Note: Data based on characterization results, not tested in production.

## 7 Package Drawings

### 7.1 LQFP32 (7x7mm, 0.8mm)

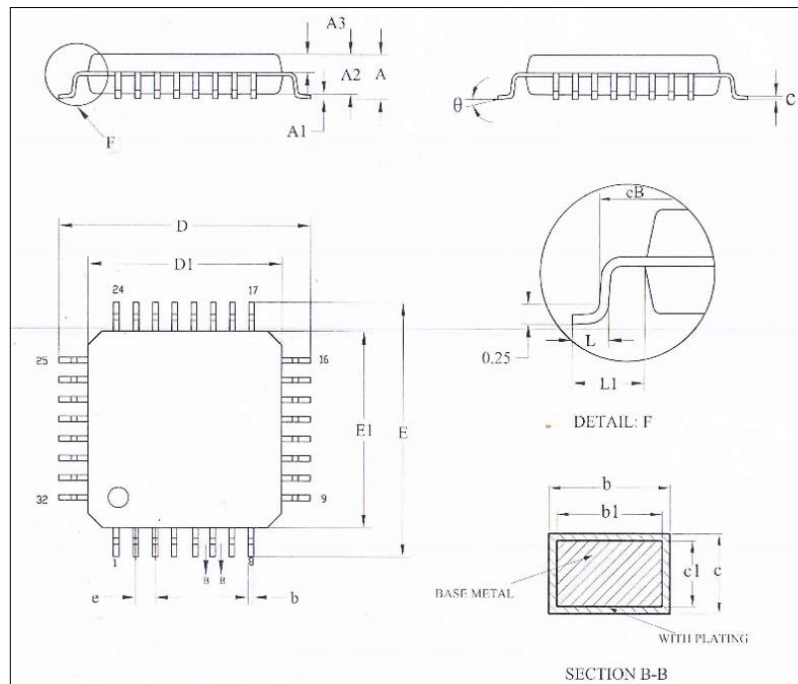

| Symbol | Millimeter |      |      |
|--------|------------|------|------|
|        | Min        | Nom  | Max  |
| A      | -          | -    | 1.60 |
| A1     | 0.05       | -    | 0.15 |
| A2     | 1.35       | 1.40 | 1.45 |
| A3     | 0.59       | 0.64 | 0.69 |
| b      | 0.33       | -    | 0.41 |
| b1     | 0.32       | 0.35 | 0.38 |
| c      | 0.13       | -    | 0.17 |
| c1     | 0.12       | 0.13 | 0.14 |
| D      | 8.80       | 9.00 | 9.20 |
| D1     | 6.90       | 7.00 | 7.10 |
| E      | 8.80       | 9.00 | 9.20 |
| E1     | 6.90       | 7.00 | 7.10 |
| eB     | 8.10       | -    | 8.25 |
| e      | 0.80BSC    |      |      |
| L      | 0.45       | -    | 0.75 |
| L1     | 1.00REF    |      |      |
| θ      | 0°         | -    | 7°   |

## 7.2 QFN32 (5x5mm, 0.5mm)

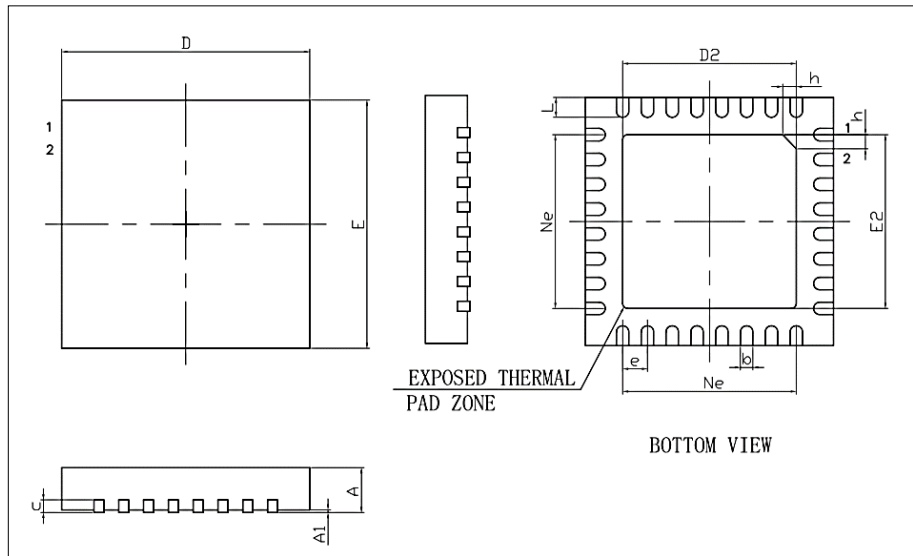

| Symbol | Millimeter |      |      |
|--------|------------|------|------|
|        | Min        | Nom  | Max  |
| A      | 0.70       | 0.75 | 0.80 |
| A1     | -          | 0.02 | 0.05 |
| b      | 0.18       | 0.25 | 0.30 |
| c      | 0.18       | 0.20 | 0.25 |
| D      | 4.90       | 5.00 | 5.10 |
| D2     | 3.40       | 3.50 | 3.60 |
| e      | 0.50BSC    |      |      |
| Ne     | 3.50BSC    |      |      |
| E      | 4.90       | 5.00 | 5.10 |
| E2     | 3.40       | 3.50 | 3.60 |
| L      | 0.35       | 0.40 | 0.45 |
| h      | 0.30       | 0.35 | 0.40 |

### 7.3 QFN40 (5x5mm, 0.4mm)

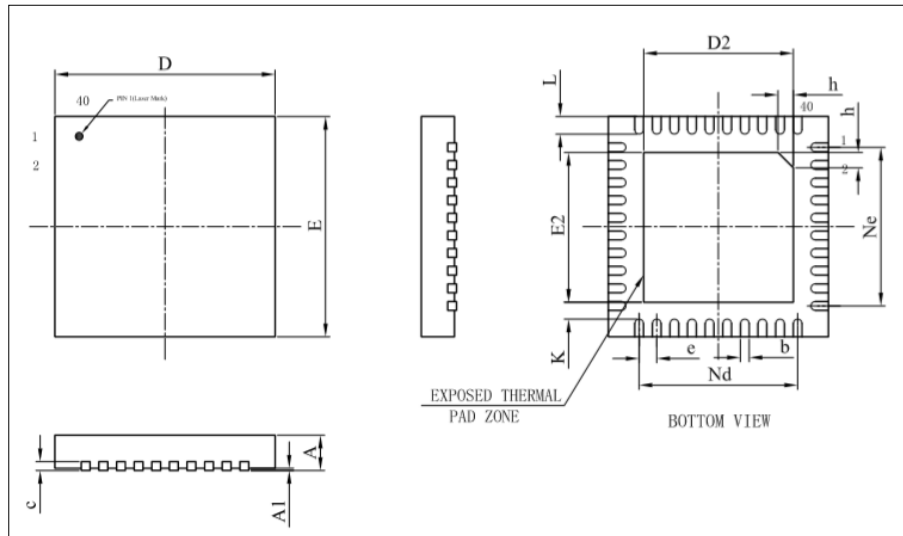

| Symbol | Millimeter |      |      |
|--------|------------|------|------|
|        | Min        | Nom  | Max  |
| A      | 0.70       | 0.75 | 0.80 |
| A1     | -          | 0.02 | 0.05 |
| b      | 0.15       | 0.20 | 0.25 |
| c      | 0.18       | 0.20 | 0.25 |
| D      | 4.90       | 5.00 | 5.10 |
| D2     | 3.30       | 3.40 | 3.50 |
| e      | 0.40BSC    |      |      |
| Nd     | 3.60BSC    |      |      |
| E      | 4.90       | 5.00 | 5.10 |
| E2     | 3.30       | 3.40 | 3.50 |
| Ne     | 3.60BSC    |      |      |
| L      | 0.35       | 0.40 | 0.45 |
| K      | 0.20       | -    | -    |
| h      | 0.30       | 0.35 | 0.40 |

## 7.4 LQFP48 (7x7mm, 0.5mm)

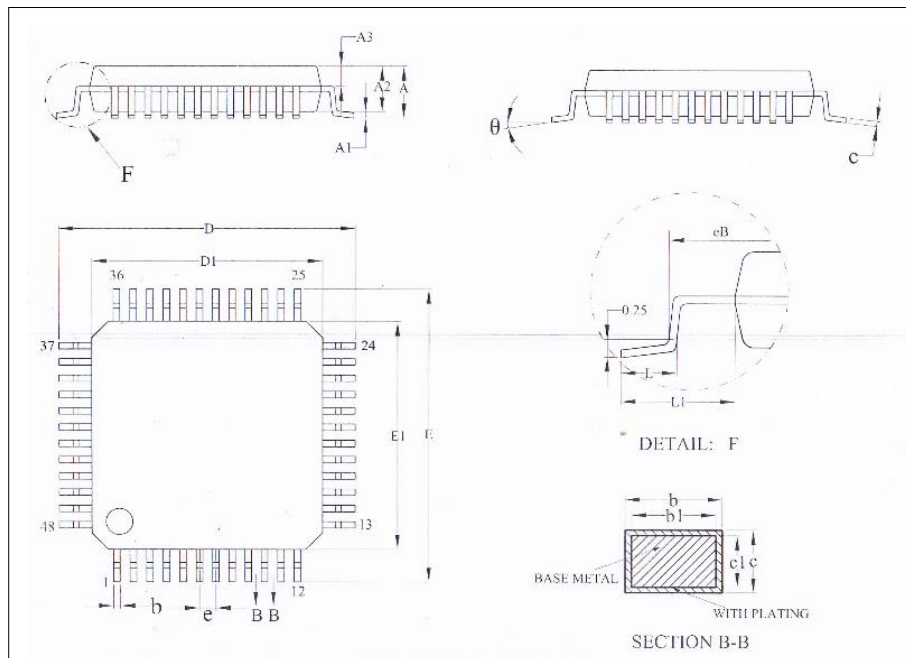

| Symbol   | Millimeter |      |      |
|----------|------------|------|------|
|          | Min        | Nom  | Max  |
| A        | -          | -    | 1.60 |
| A1       | 0.05       | -    | 0.15 |
| A2       | 1.35       | 1.40 | 1.45 |
| A3       | 0.59       | 0.64 | 0.69 |
| b        | 0.18       | -    | 0.26 |
| b1       | 0.17       | 0.20 | 0.23 |
| c        | 0.13       | -    | 0.17 |
| c1       | 0.12       | 0.13 | 0.14 |
| D        | 8.80       | 9.00 | 9.20 |
| D1       | 6.90       | 7.00 | 7.10 |
| E        | 8.80       | 9.00 | 9.20 |
| E1       | 6.90       | 7.00 | 7.10 |
| eB       | 8.10       | -    | 8.25 |
| e        | 0.50BSC    |      |      |
| L        | 0.45       | -    | 0.75 |
| L1       | 1.00REF    |      |      |
| $\theta$ | 0°         | -    | 7°   |

## 8 Revision History

| Rev.  | Date       | Description  |
|-------|------------|--|
| V1.00 | 2020.12.30 | First Version Issue  |
| V1.40 | 2023.2.20  | <ol style="list-style-type: none"><li>1) 6.9, 6.10: Added subsections of 6.9, 6.10 characteristic descriptions.</li><li>2) 6.4.2, 6.8.2: Added notes on parameters for low temperature conditions.</li><li>3) 1.2, 1.3, 7.1: Added product descriptions for QFN32 package.</li><li>4) 4.1, 4.3: Added port type descriptions.</li><li>5) 6.8: Modified some specification values for analogue characteristics.</li><li>6) Full text: Uniformed the format.</li></ol> |